



The influence of reinforcement architecture on the static and dynamic behaviour of composites

Dr. Katleen Vallons
KU Leuven, dept. of Materials Engineering
Belgium

Outline

- Composites
- Reinforcements for composites
- Influence of reinforcement architecture on behaviour
 - Stiffness
 - Damage
 - Strength
 - Fatigue
 - Toughness and impact
- Summary

Composites



Introduction

- **“Composites”**

= combination of two or more materials

- To merge the good properties of both materials in the new material (e.g. reinforced concrete)
- To create new interesting properties (e.g. impact resistance)

- **“Fibre Reinforced Polymer” (FRP)**

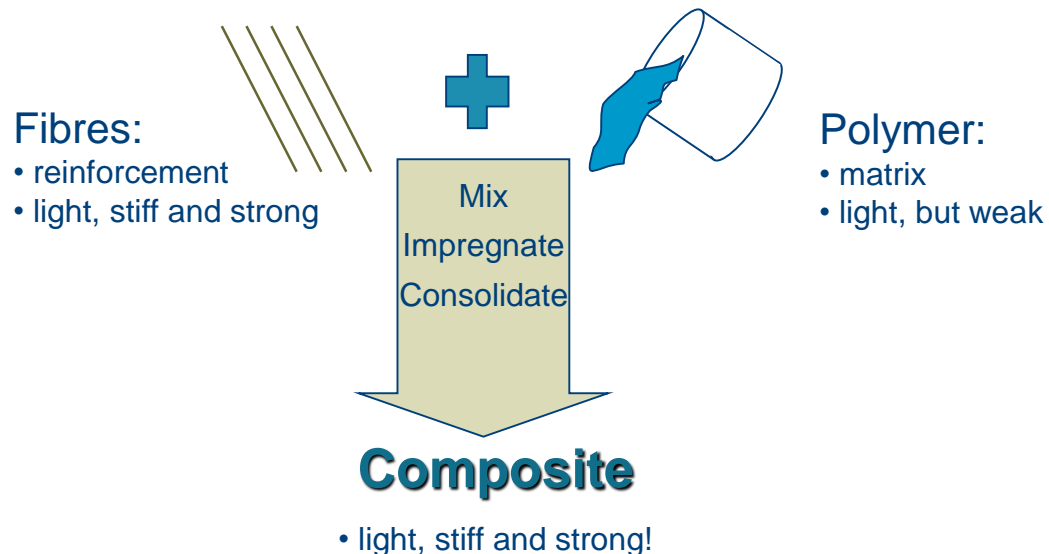

Typical materials

- **Fibres**

- Carbon (anisotropic, high strength, stiffness, low density, high price)
- Glass (isotropic, lower properties, higher density, lower price)
- Natural fibres: flax, hemp,... (properties similar to glass)
- Others (PE, Aramid,...)

- **Matrix**

- Thermoset: epoxy, polyester, vinylester,...
- Thermoplastic: PP, PEEK, PA, ...

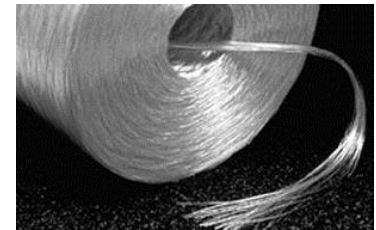

FRP - applications



Fibre reinforced polymers – why

- Very high specific properties
 - Specific stiffness

FRP – specific stiffness

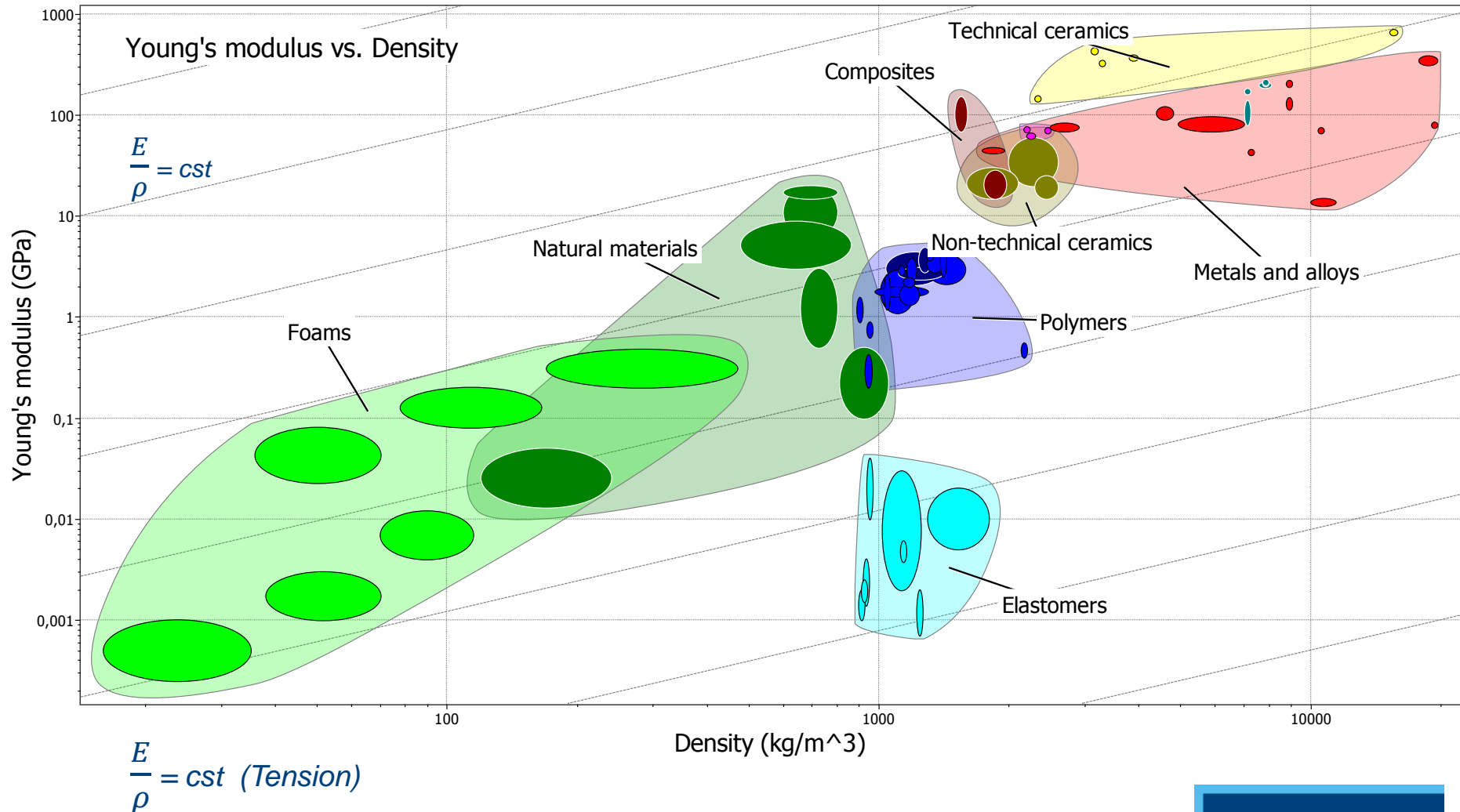

FRP – specific stiffness

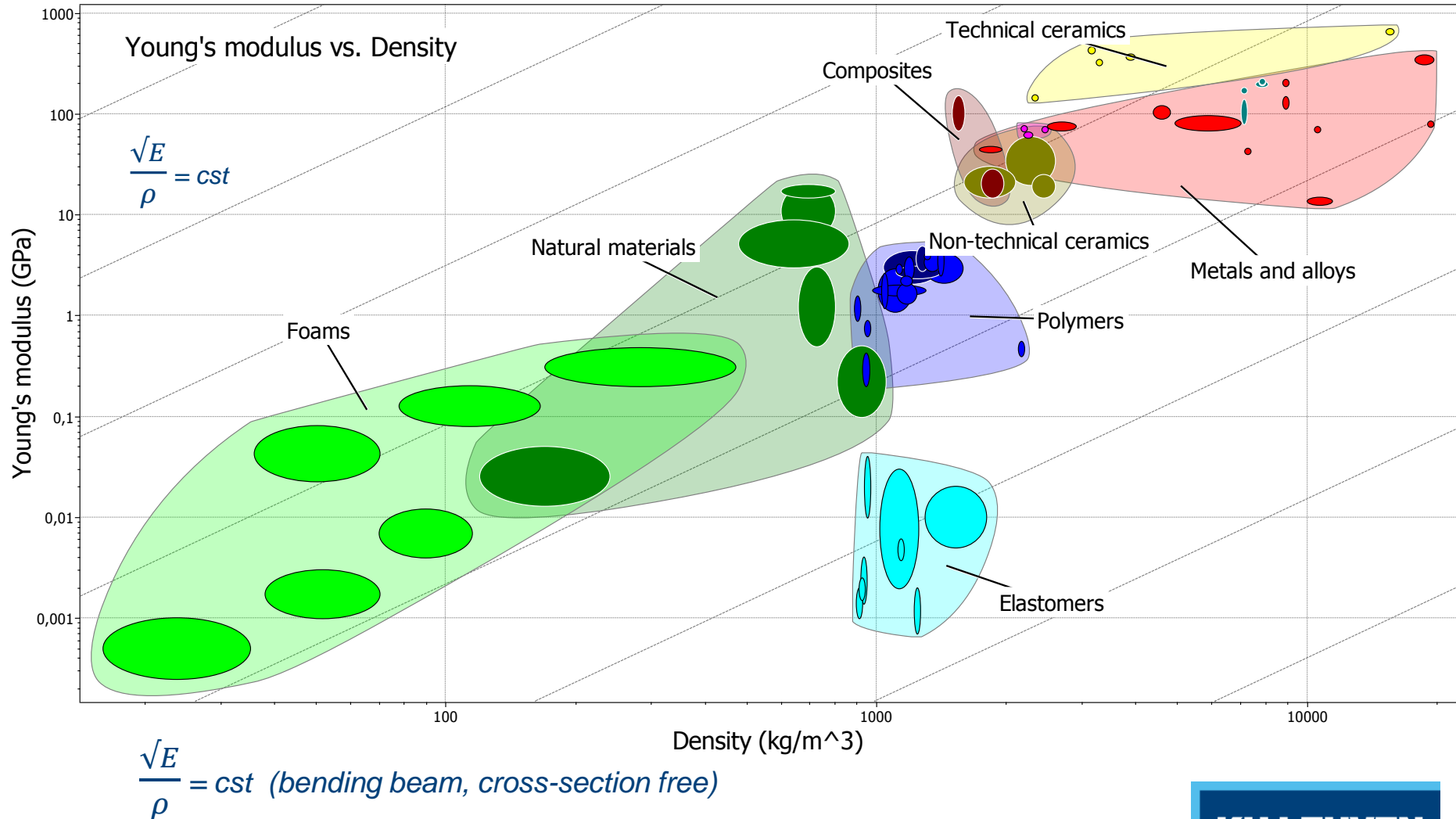

Fibre reinforced polymers – why

- Very high specific properties
 - Specific stiffness
 - Specific strength

FRP – specific strength

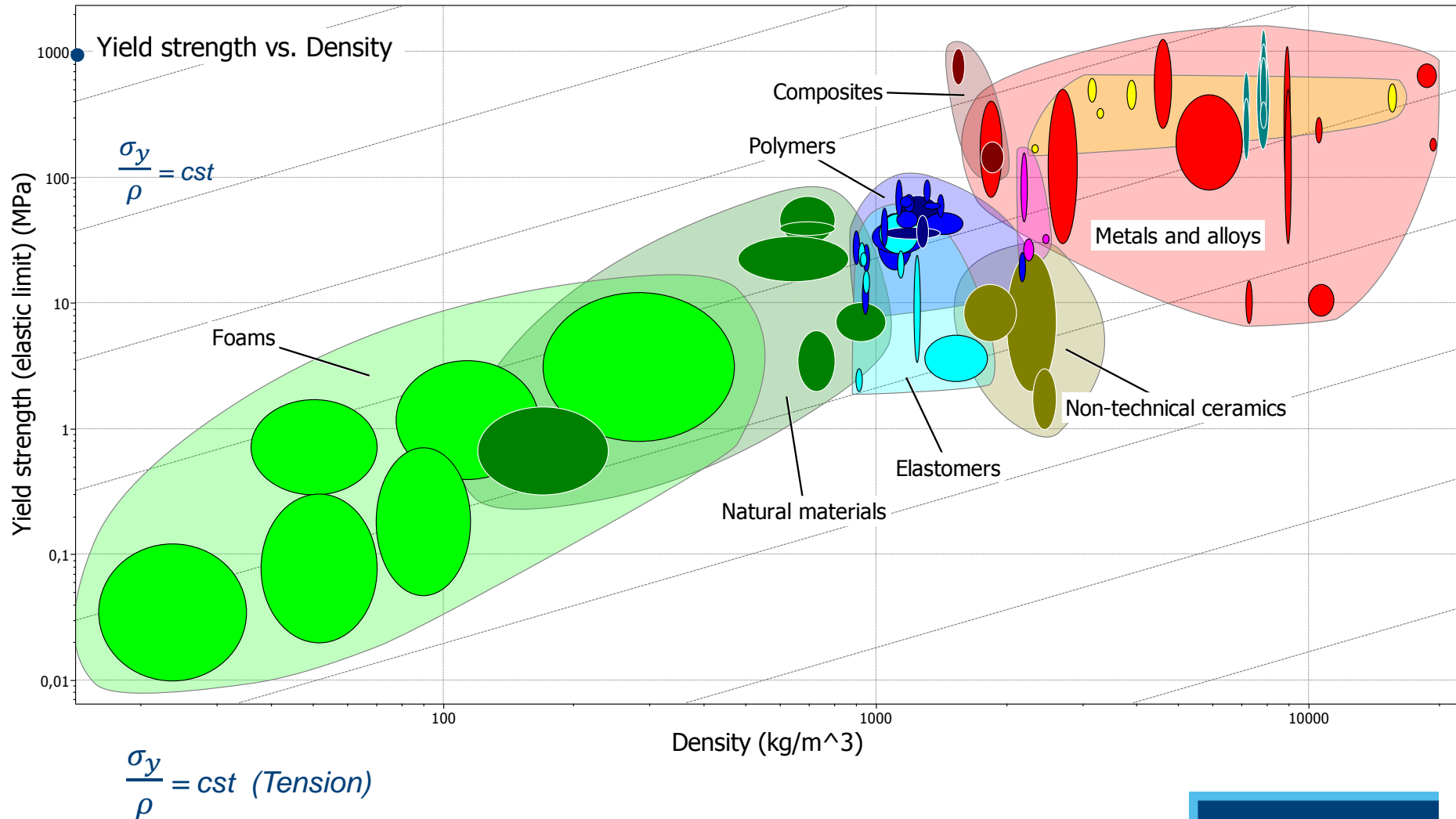

FRP – specific strength

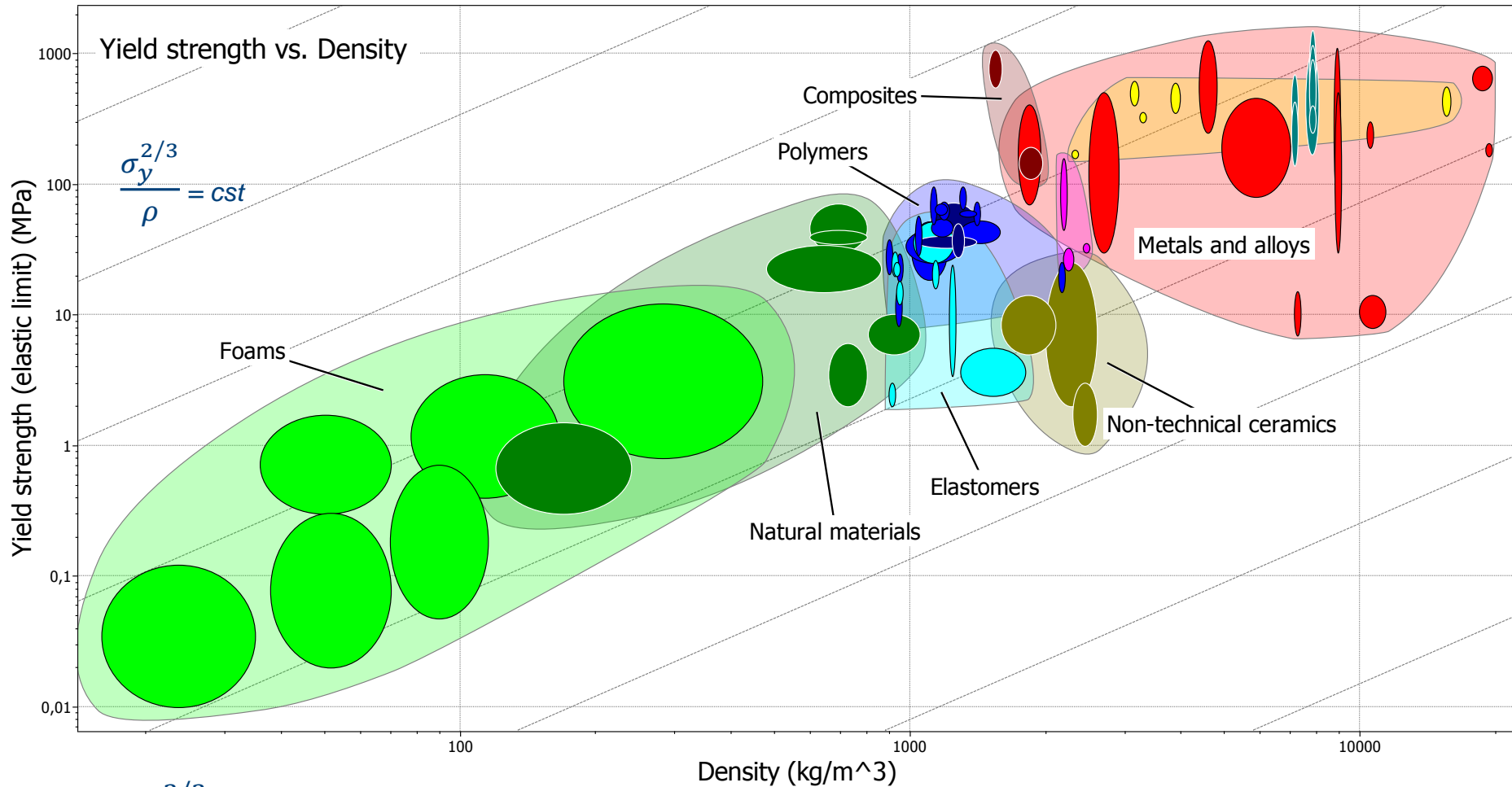

$\frac{\sigma_y^{2/3}}{\rho} = cst$ (bending beam, cross-section free)

Fibre reinforced polymers – why

- Very high specific properties
 - Specific stiffness
 - Specific strength
- Impact and crash properties:
 - Damage in FRP:
 - fibre failure, debonding, delamination, matrix cracking...
 - High absorbed energy
- Other reasons
 - thermal/electrical conductivity
 - ...

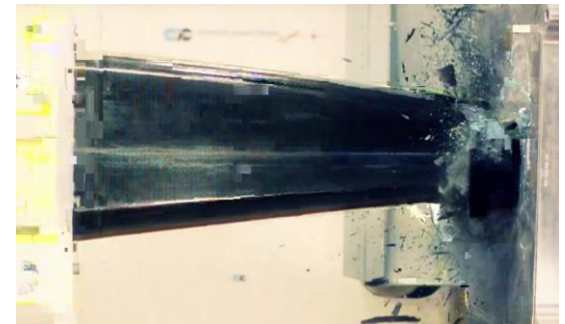

Fibre reinforced polymers – why not

- Material cost
- Complex design
- Complex production
- Recyclability

Classification of FRP

- Can be based on:
 - Matrix material:
 - Thermoplastic, e.g. PP
 - Thermoset, e.g. epoxy, polyester
 - Fibre material
 - Glass
 - Carbon
 - aramid, natural fibres, ...
 - Reinforcement architecture

Types of reinforcement for FRP



Types of FRP reinforcement

Reinforcements

Types of FRP reinforcement

- UD layers:

Production:

- Pre-impregnated partially cured sheets (prepregs)
- Manual or robotic lay-up
- Autoclave process (T,t,P)

→ “perfect” composite: straight, aligned fibres, free orientations, high V_f , low defect fraction...

But: limited shelf-life, complex and costly
→ only high-performance e.g. aerospace



Types of FRP reinforcement

- Alternative?

Textile = structurally 'stable' arrangement of dry fibres (= fabric)

- Improved storage
- Improved handling, draping
- Improved permeability
→(cheaper) infusion production techniques possible
- Loss of some quality, less perfect orientations, less orientation freedom

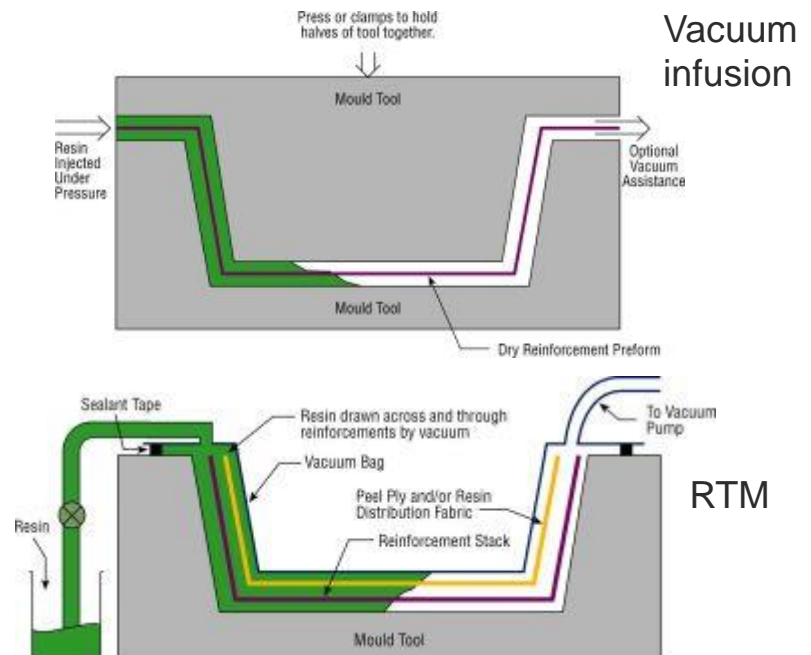

<http://www.composites.ugent.be/>

Types of FRP reinforcement

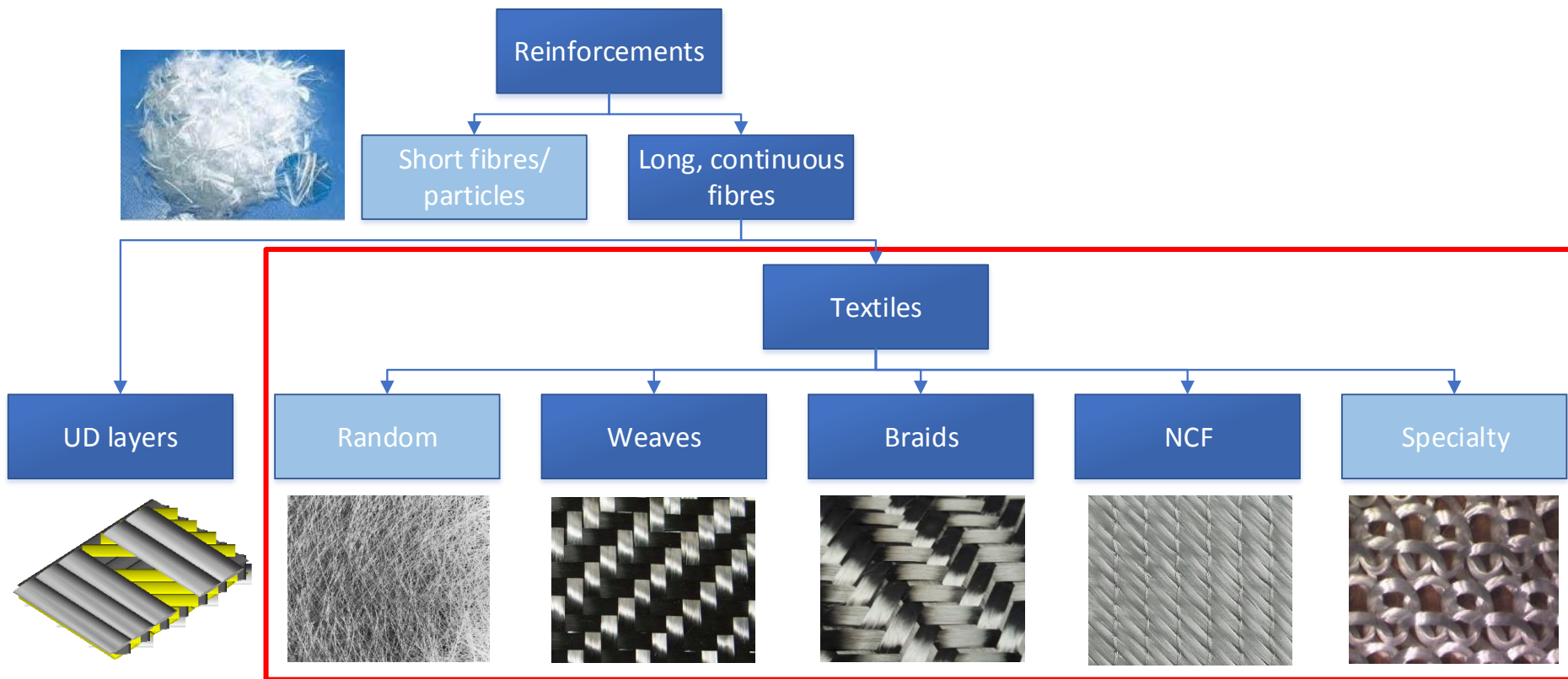

Random fibre textiles

- Continuous or 'long short' fibres
- Integrity < chemical or physical fixation
- Random fibre orientation → isotropy

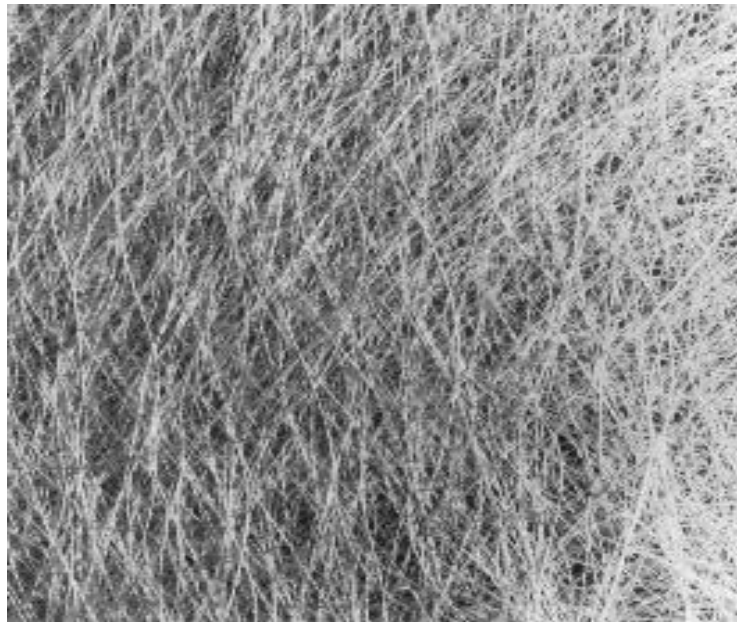

Woven fabrics

- Bundles interlaced in two orthogonal fibre directions
- Different weaving patterns
- More open structure than UD

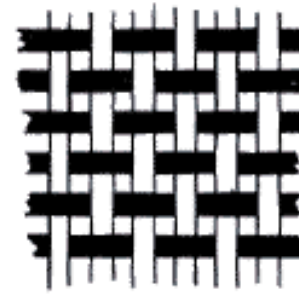
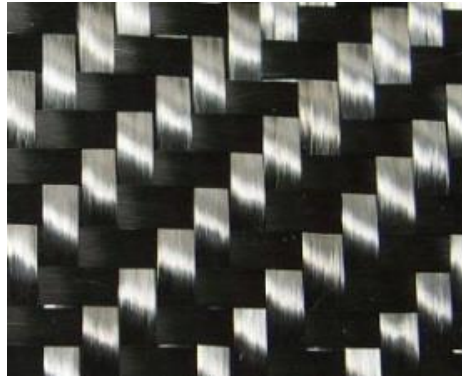

Plain Weave

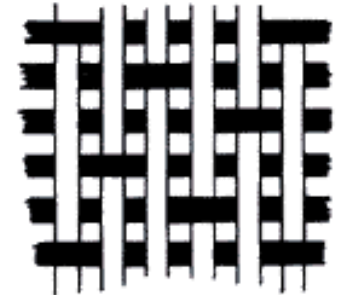

5-Harness Satin Weave

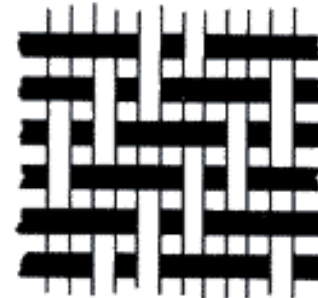

2/2 Twill Weave

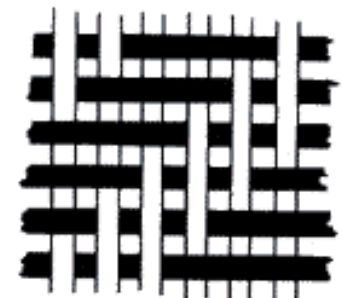

3/3 Twill Weave

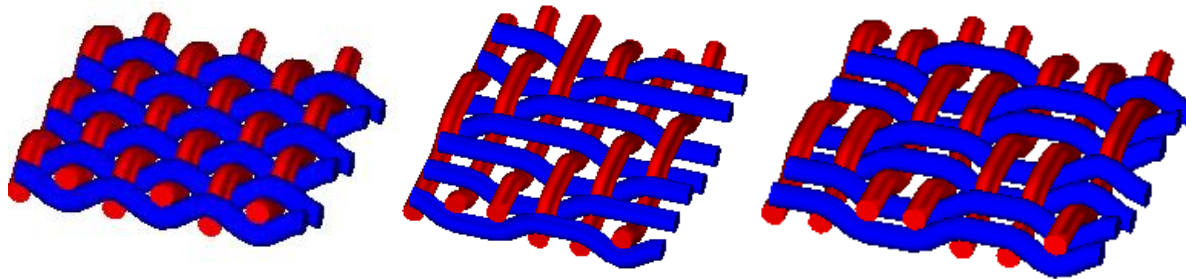

Braided fabrics

- Mostly tubular production
- Similar structure to weaves, but angle = variable
- Biaxial or triaxial if with inlays
- Overbraiding of a structure possible

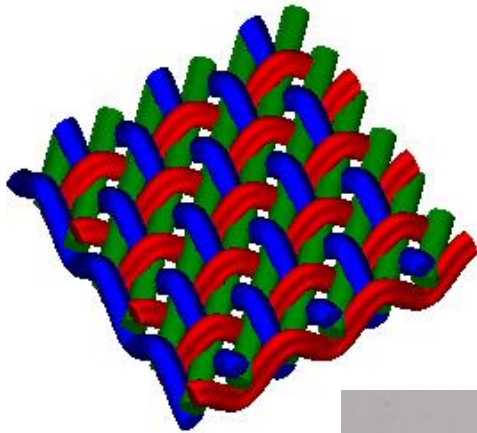
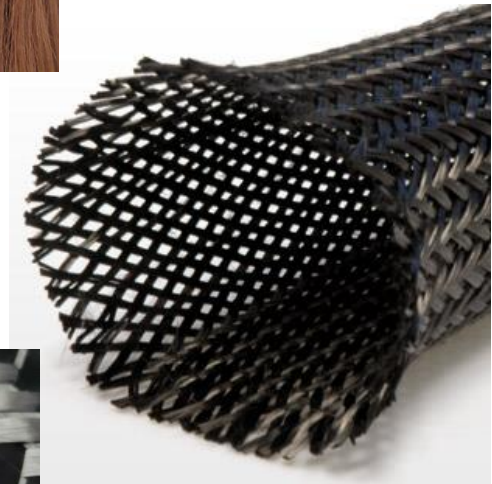

<http://www.epicos.com/>

Non-crimp fabrics

- UD fibre layers stitched together
- Different orientations
- (non-)structural stitching
- Different patterns

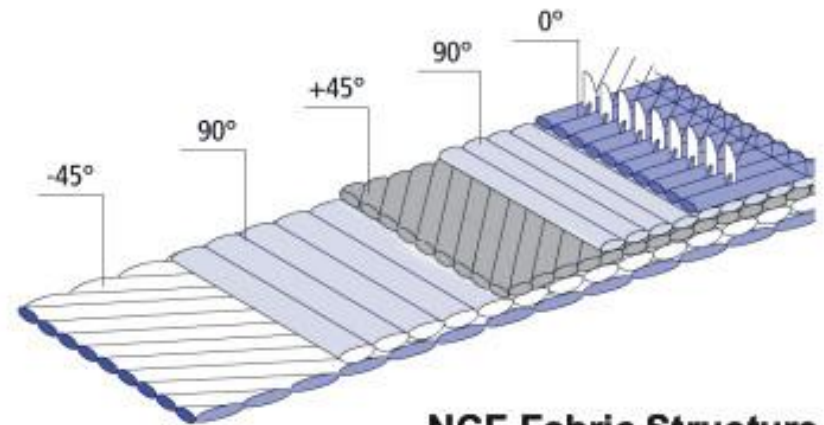

NCF Fabric Structure
www.poliya.com

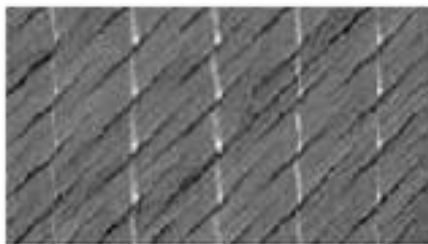

Chain

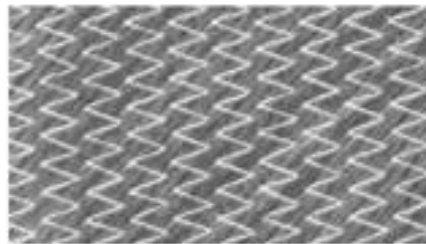

Tricot

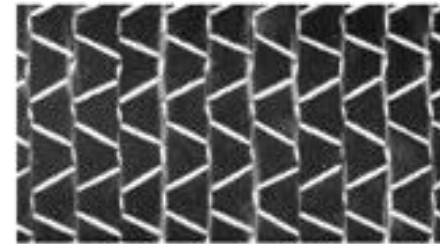

Tricot-chain

Non-crimp fabrics

- Channels/openings created by stitching
(Dependent on fibre orientation and stitching pattern)

Unit cell $\pm 45^\circ$ NCF

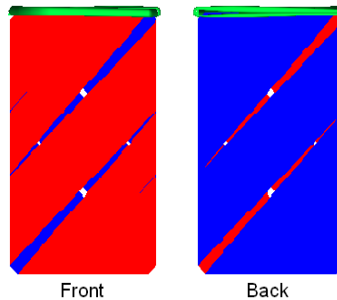
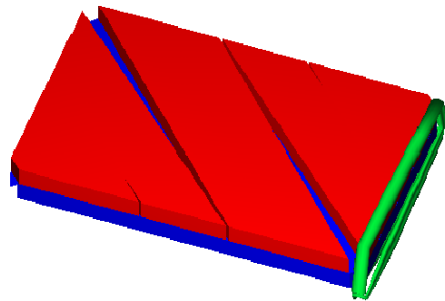

Unit cell $0/90^\circ$ NCF

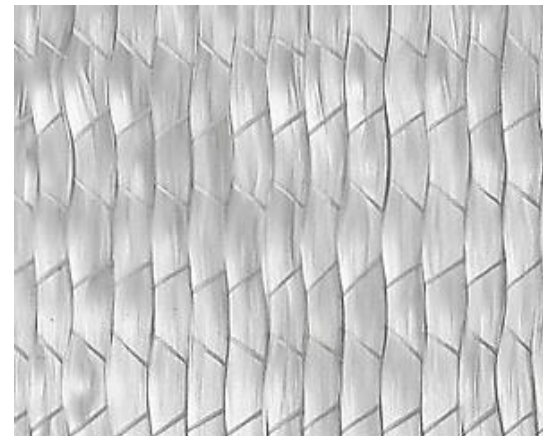
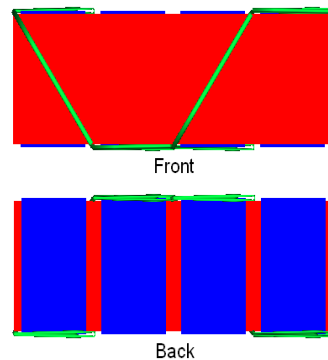
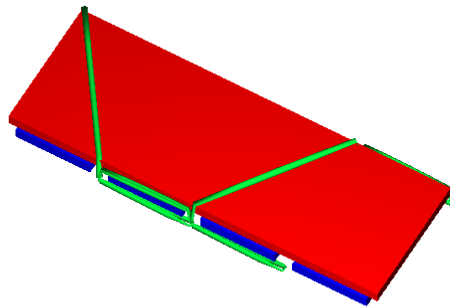

Specialty fabrics

- Knitted fabrics:
 - Regular but widely distributed fibre orientation

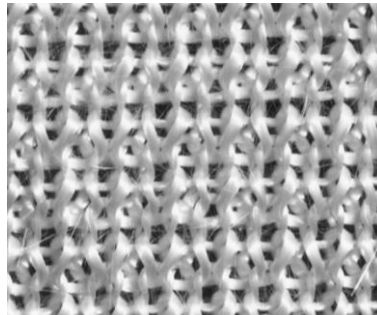
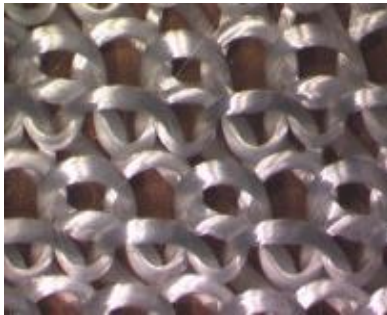

Leong et al, ICCM12, 1999

- 3D fabrics
 - 3D Weaves, 3D braids
- ...



www.axis-composites.com

Influence of the reinforcement architecture on the FRP properties



Influence of reinforcement

- Orientation in composites
- Textile crimp
- Mechanical behaviour
 - Stiffness
 - Damage development
 - Strength
 - Fatigue
 - Toughness and impact

Fibre orientation in composites

- Orientation of fibres vs. load is key in FRP:
 - Off-axis loading in UD composite:

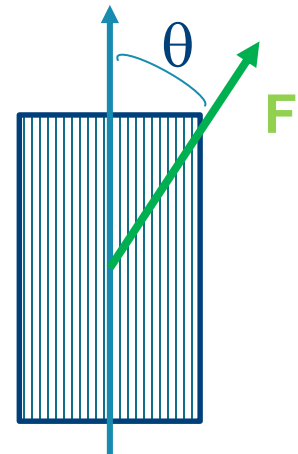
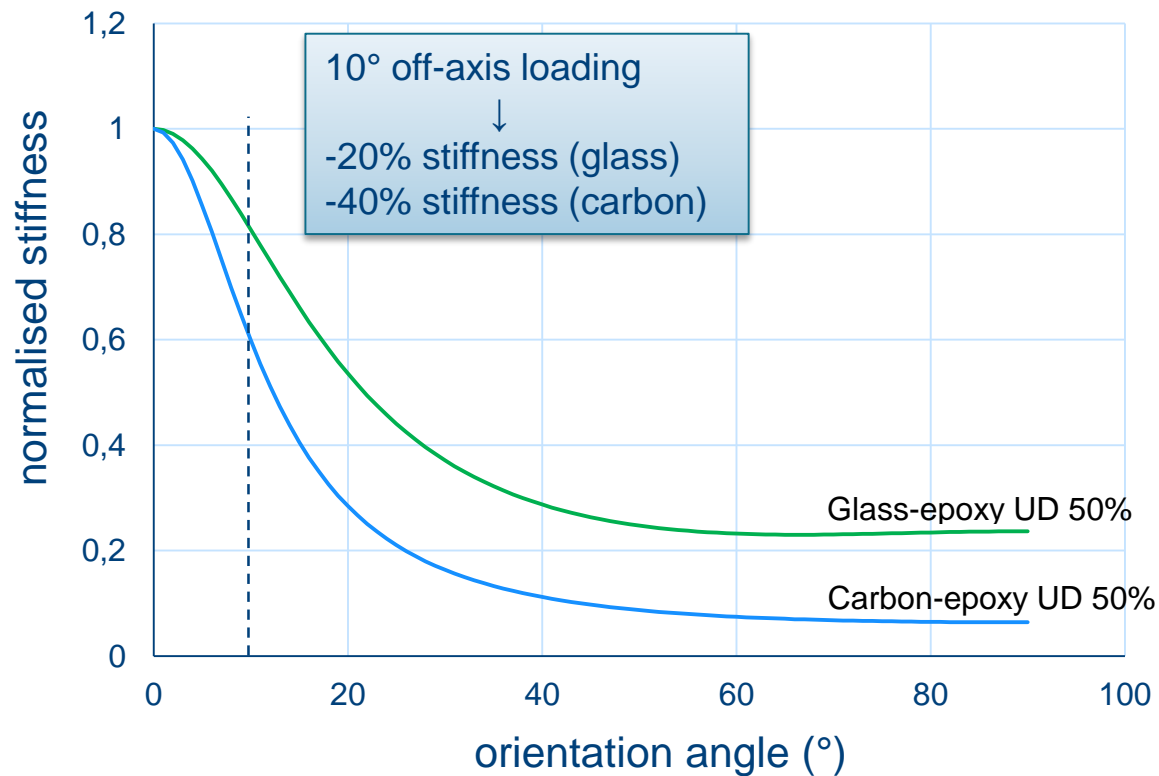

Crimp

- UD (prepreg): fibres = straight, aligned with load
- Textile: 'crimp'

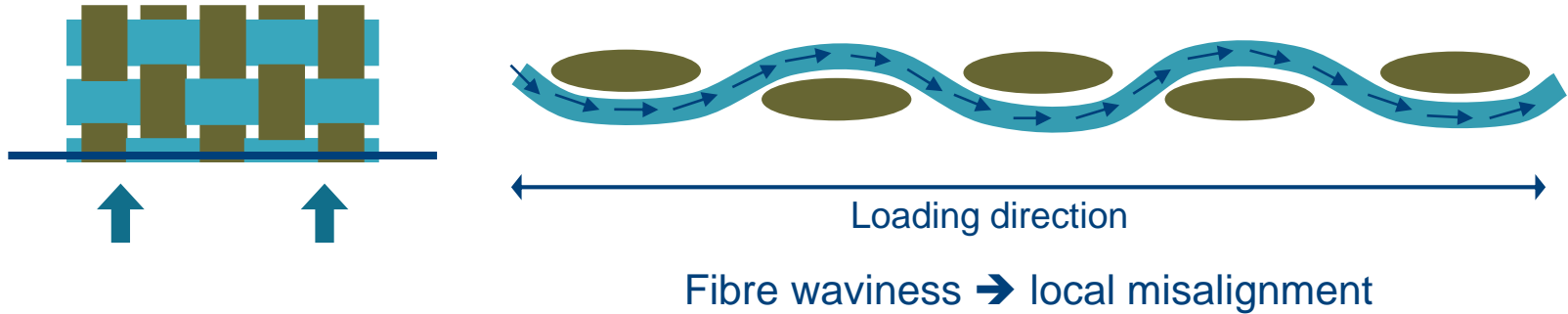

$$\text{percentage of "crimp"} = \frac{\text{actual length of fibre bundle} - \text{fabric length}}{\text{fabric length}} \times 100$$

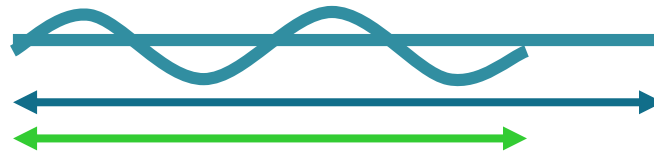

Crimp

- Woven fabric (+ braided):

- Out-of-plane
- Dependent on:
 - Tow spreading: \uparrow crimp \downarrow

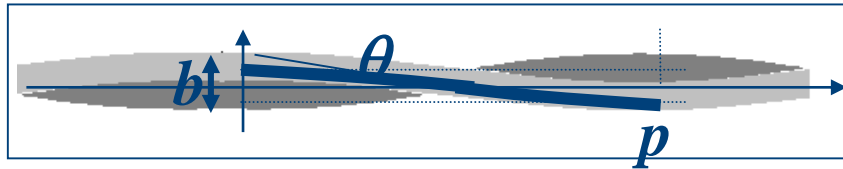

- Pattern: float length \uparrow crimp \downarrow

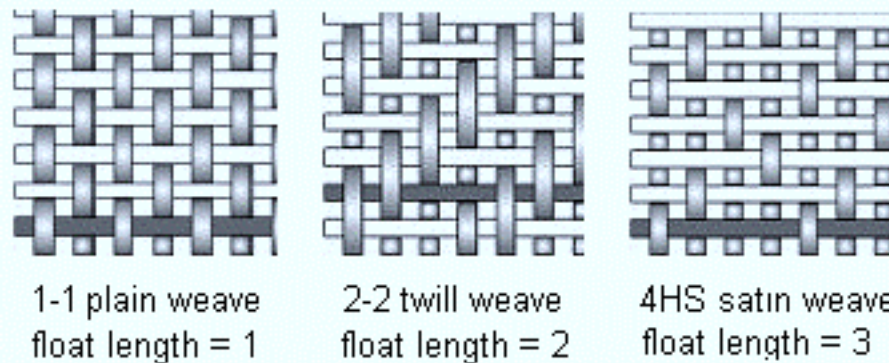

- Ends/picks

b/p	$c, \%$	$\theta, ^\circ$	
0.05	0.04	0.95	
0.1	0.15	1.91	
0.2	0.60	3.81	
0.5	3.65	9.46	
1	13.7	18.4	

Crimp

- Non-crimp fabric:
 - ~~'No crimp'~~ → Limited in/out-of-plane waviness
 - Stitching pushes bundles aside
 - Determined by tension on stitching yarn, fibre orientation angle,...

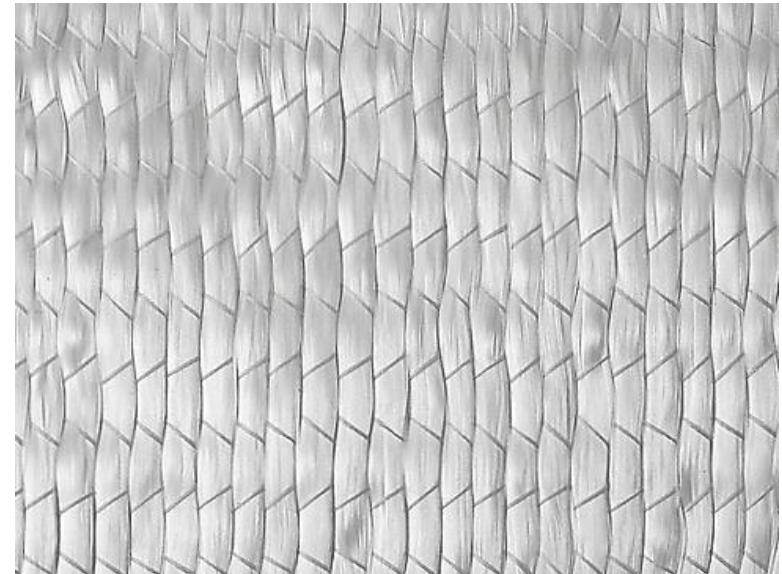
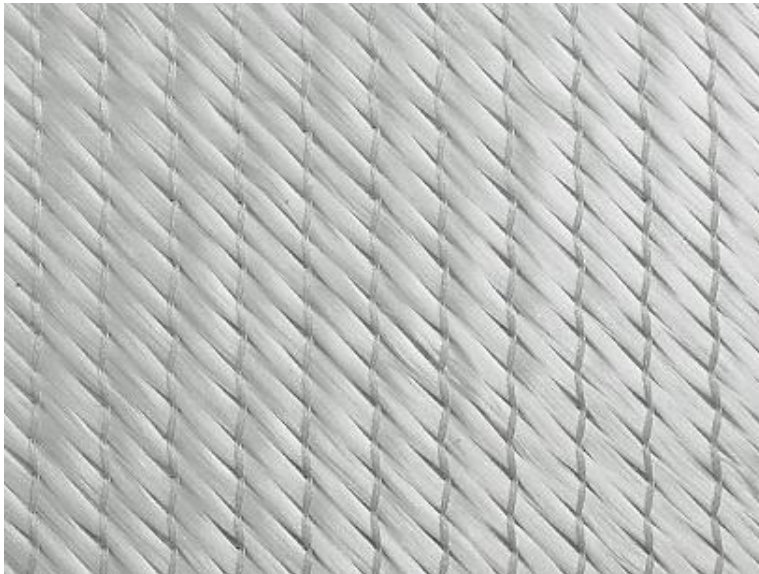

Stiffness

- Effect of crimp



Average orientation $\theta \neq 0$

→ Lower stiffness

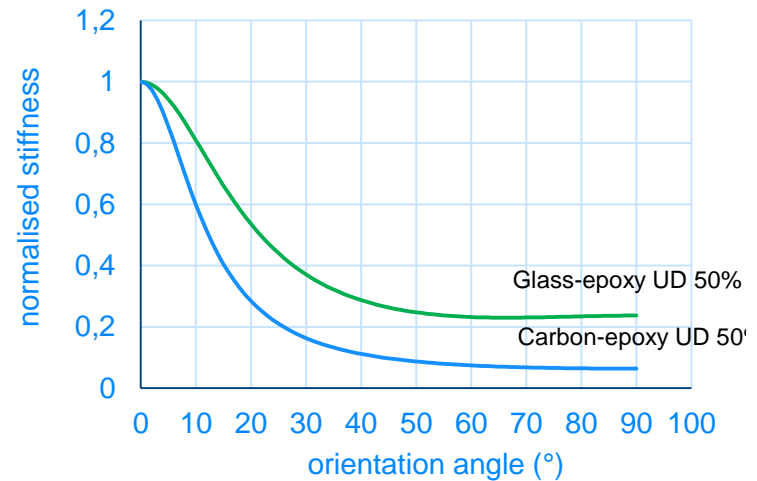

Stiffness

NCF composite

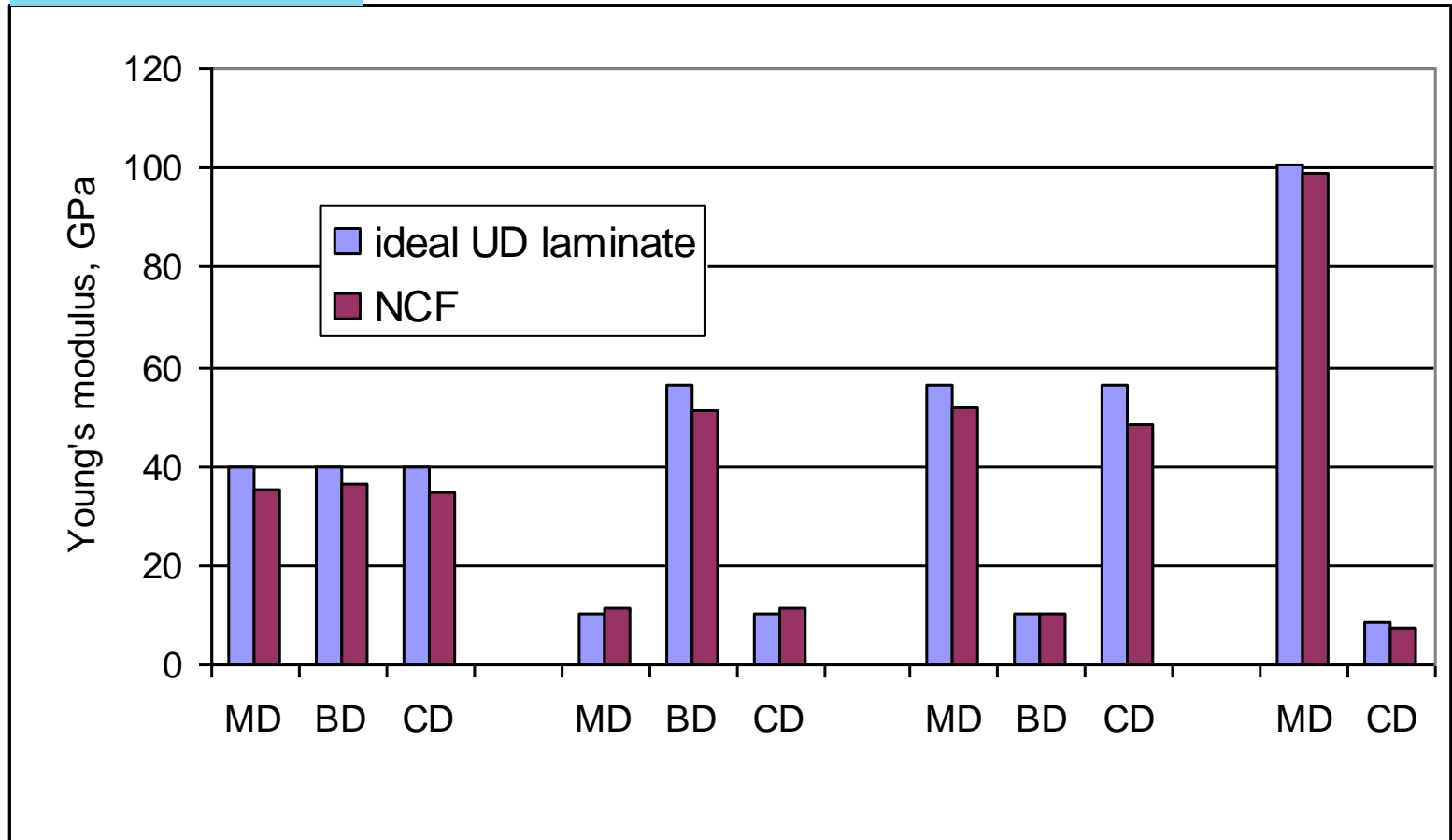

S.V. Lomov - Textile Preforms for Composites

differences < 10%

Stiffness

NCF composite (Q-UD glass – epoxy)

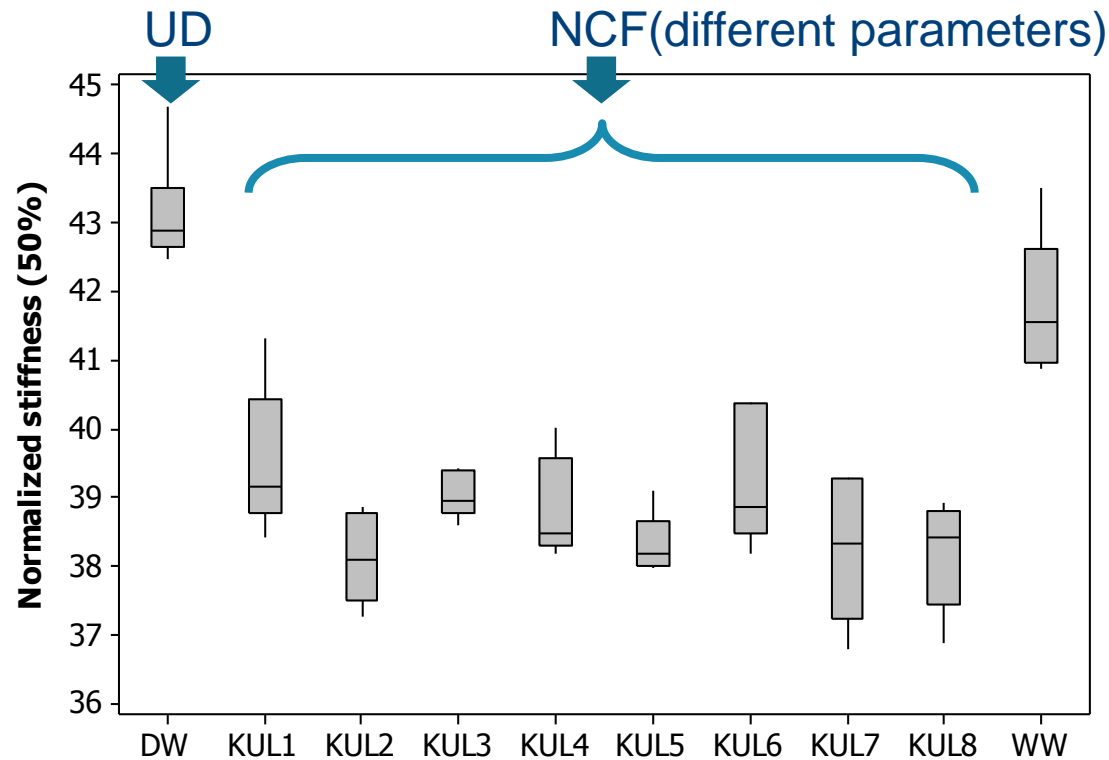

Stiffness

Woven fabric composite

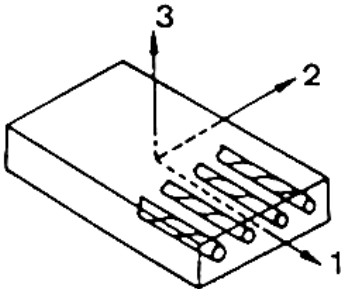
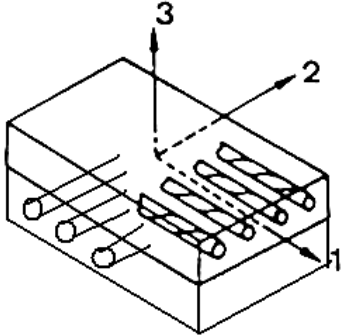
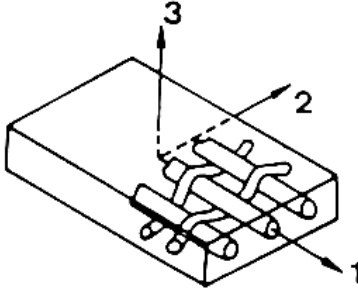
	UD 0°	UD 0/90	Woven
			
E1, GPa	38.6	26.9	23.6
E2, GPa	8.3	26.9	23.6
ν_{12}	0.26	0.09	0.12
G, GPa	4.1	4.1	6.2

V_f = 60%
E-glass / epoxy

S.V. Lomov - Textile Preforms for Composites

1% increase in crimp → stiffness decrease ~10% (glass!)

≠ weave pattern → ≠ crimp → ≠ stiffness

Damage development

- 0/90 UD based composites under tensile load:

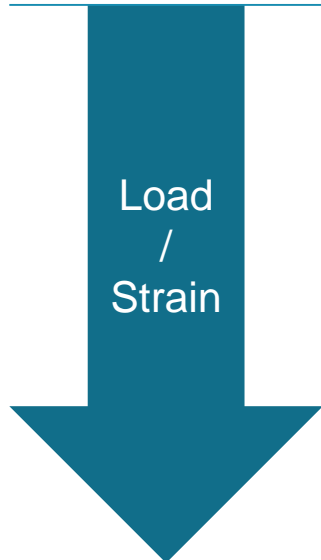

- Initiation matrix cracks in 90°plies
- Growth matrix cracks
- 0° splitting and initiation of local delaminations
- Minor delamination growth
- Fibre failure

→ Limited effect on stiffness until final failure

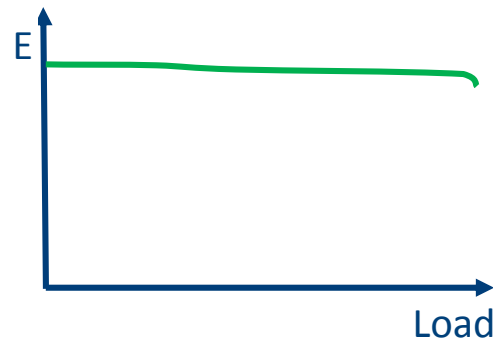

Damage development

- Woven fabric composites:
 - Transverse matrix cracks – small decrease in modulus
 - Longitudinal cracks + meta-delaminations at interlacing points – gradual decrease in modulus
 - Large scale delamination – rapid decrease in modulus
 - Final fibre failure

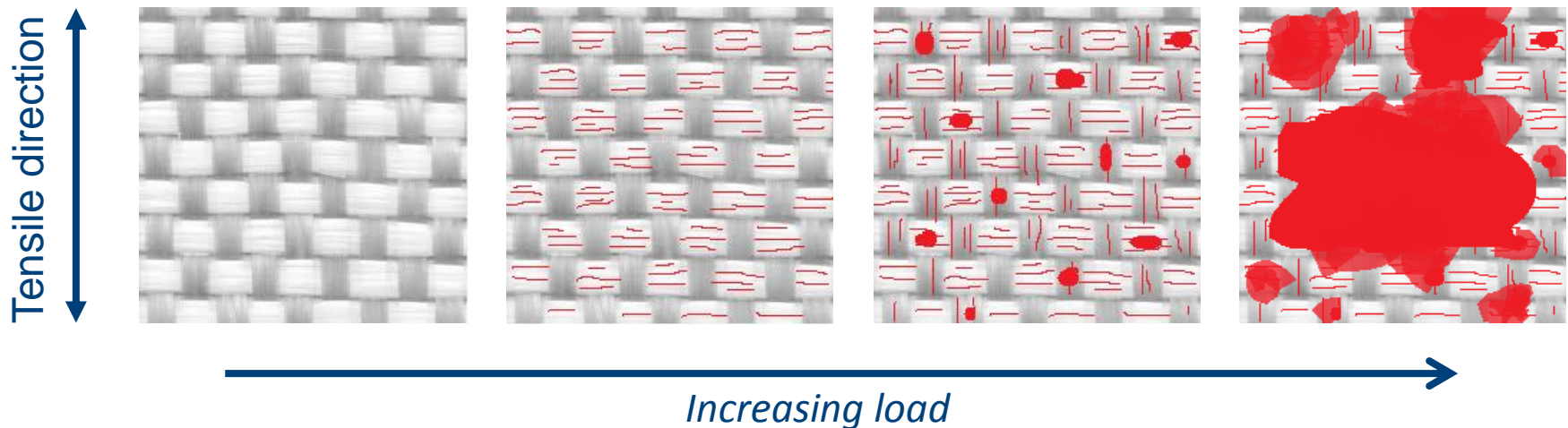

Damage development

- Woven fabric composites:
 - More pronounced stiffness decrease (< delaminations)

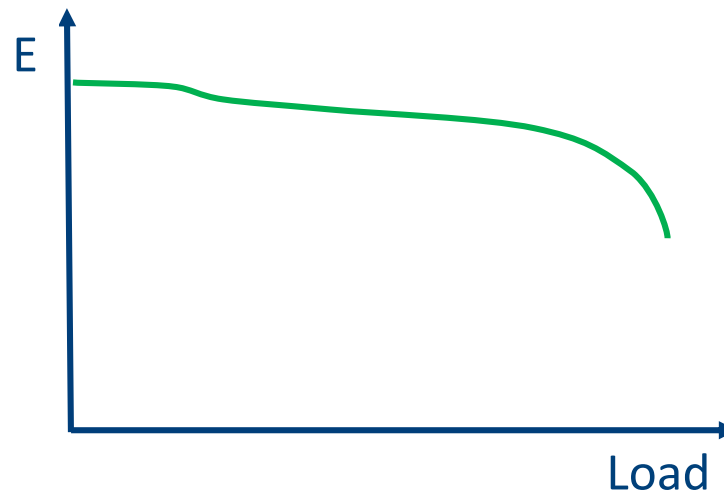

Effects are larger for weaves with higher crimp and more interlacing points

Plain > twill > satin

Damage development

- Woven fabric composites: Note: some damage types can be suppressed by using a tough matrix

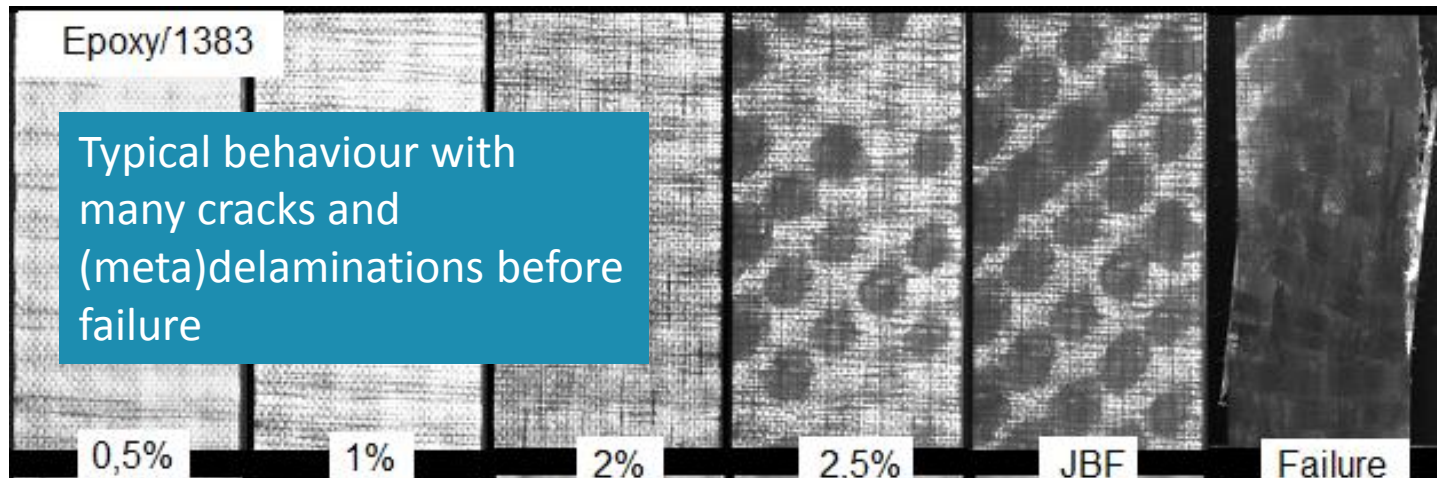

Matrix cracking is delayed and formation of (meta)delaminations quasi completely suppressed

Damage development

- Non-crimp fabric composites:
 - Damage development similar to UD, but some peculiarities

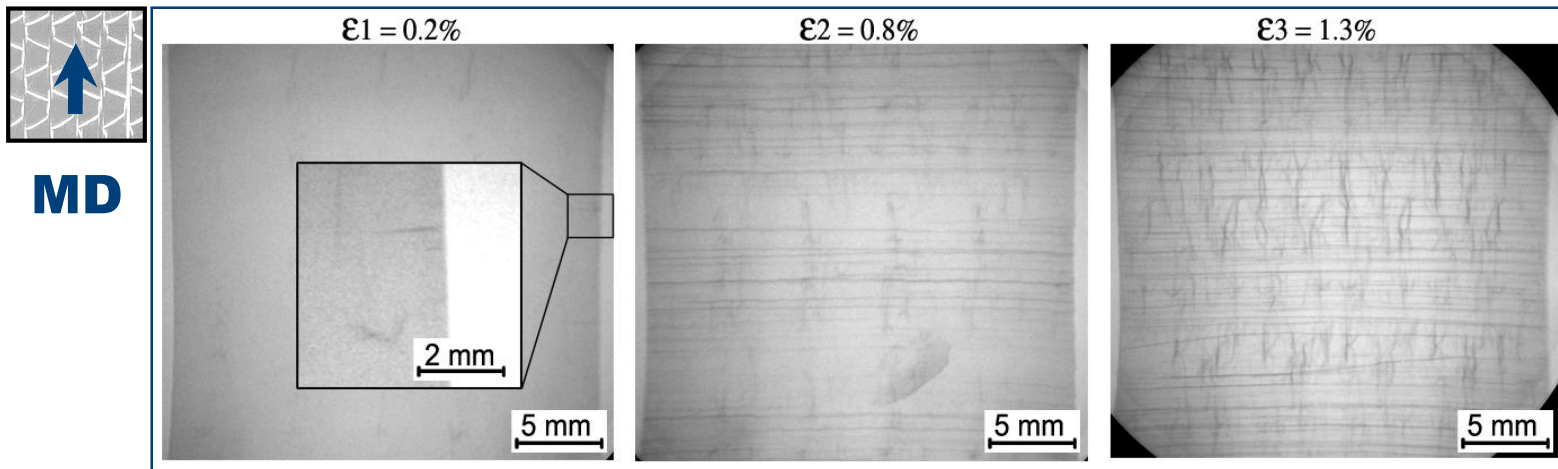

S.V. Lomov - Textile Preforms for Composites

Damage development

- Non-crimp fabric composites:
 - Damage development similar to UD, but some peculiarities
 - Stitching sites → resin rich zones → stress concentrations

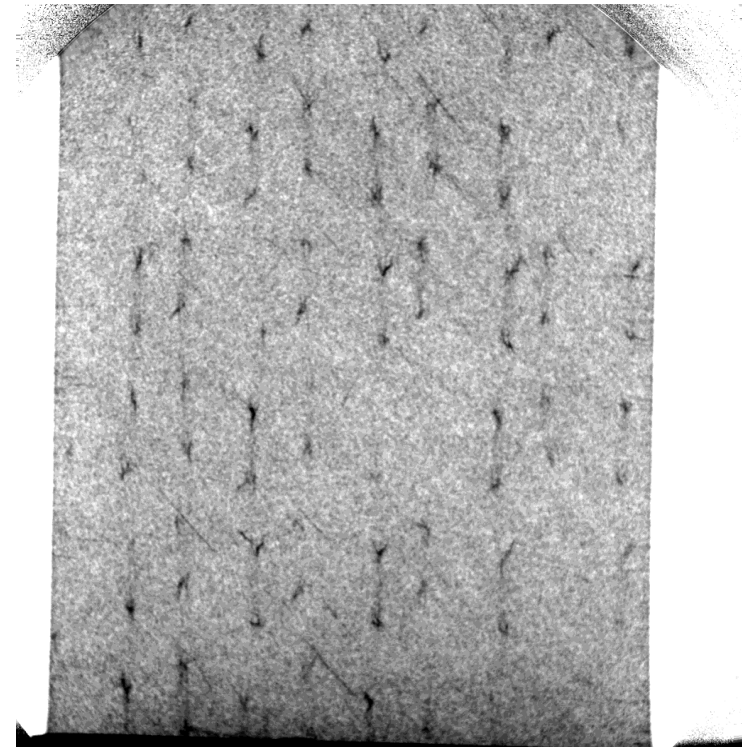
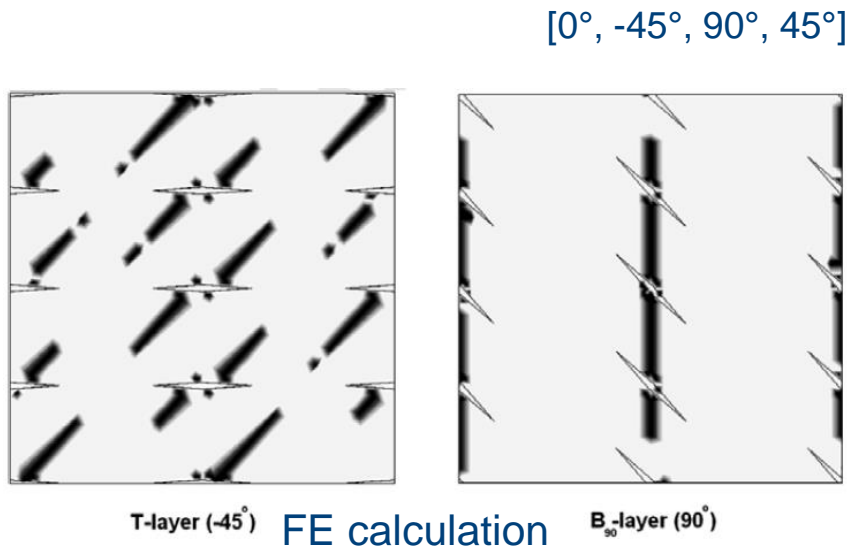

S.V. Lomov - Textile Preforms for Composites

Damage development

- Non-crimp fabric composites:
 - Damage development similar to UD, but some peculiarities
 - Stitching sites → resin rich zones → stress concentrations
 - Initiation earlier than in UD

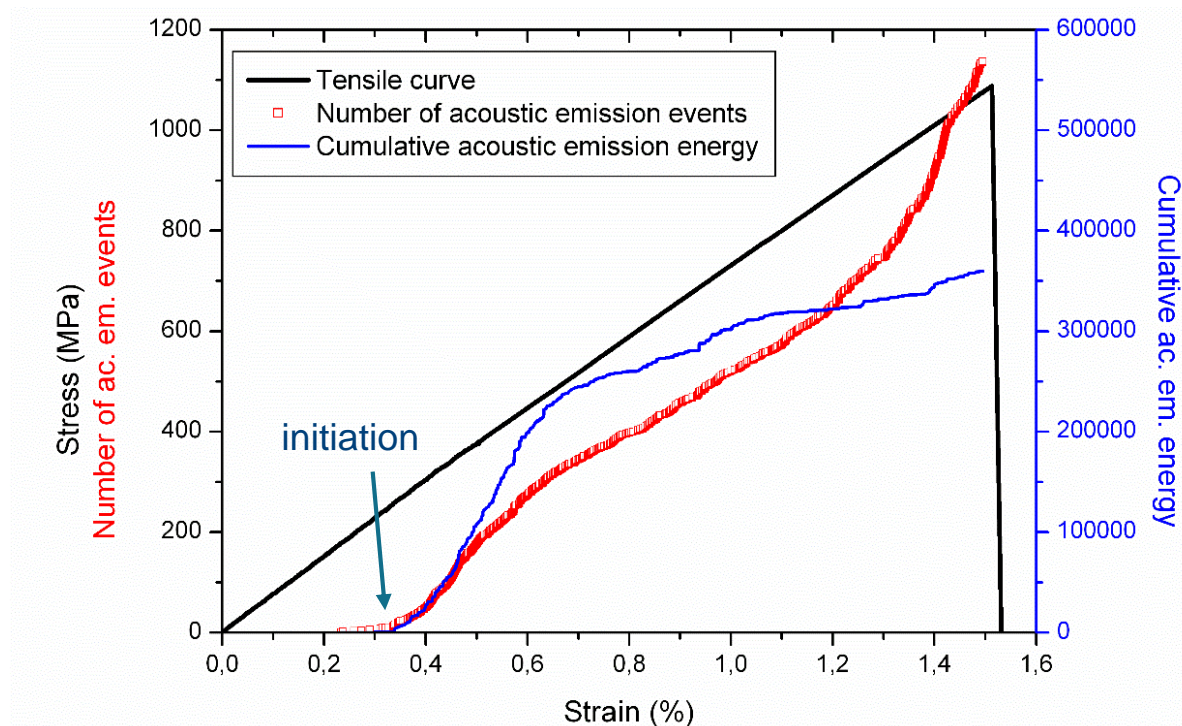

Strength

- Fibre-direction tensile strength

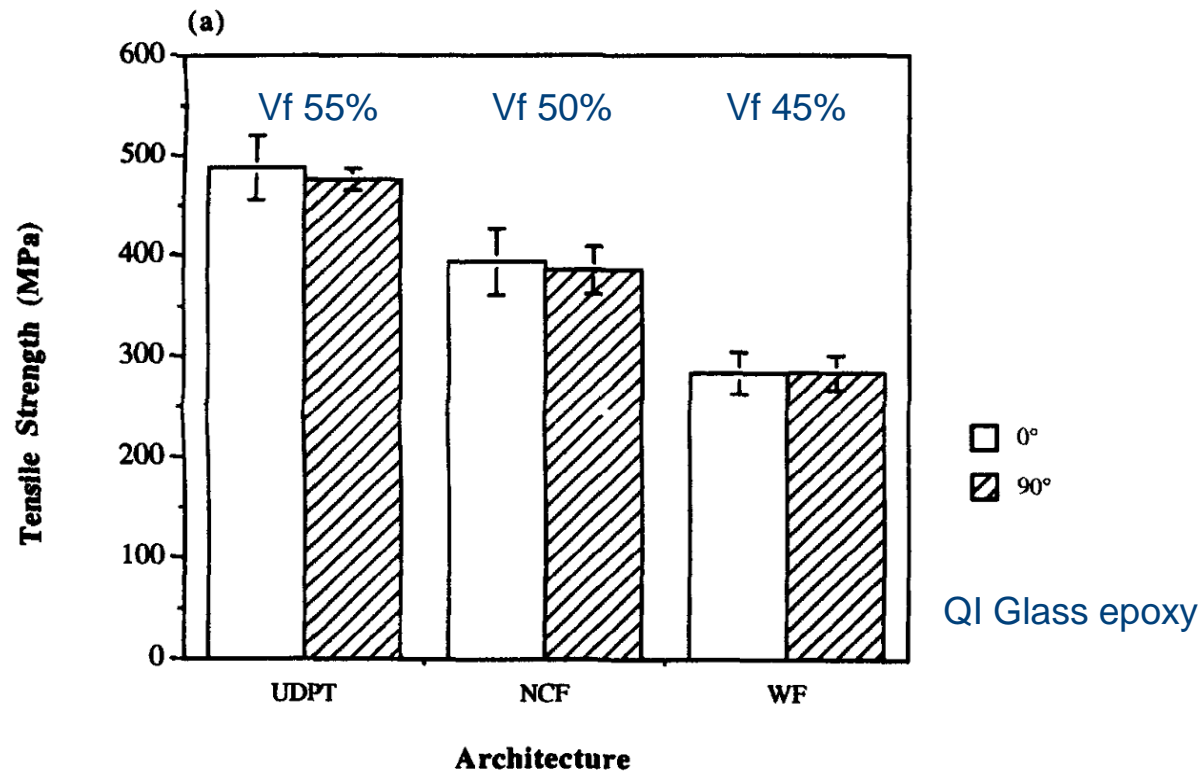

G. A. Bibo, P. J. Hogg, and M. Kemp, *Compos Sci Technol*, vol. 57, no. 9–10, 1997.

Strength

- Fibre-direction tensile strength

Note: stitching pattern in NCF can cause differences in strength

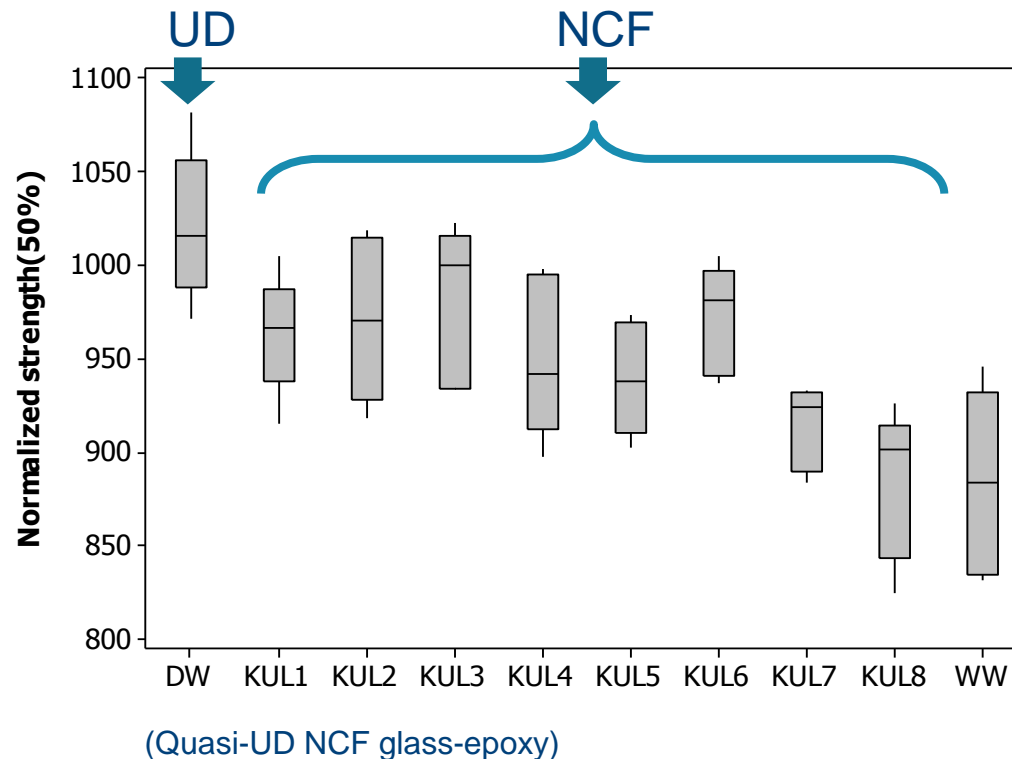

Strength

- Bias-direction tensile strength
 - → Typically: woven >> NCF ≥ UD
 - Interlacing effect in woven fabric composites increases strength

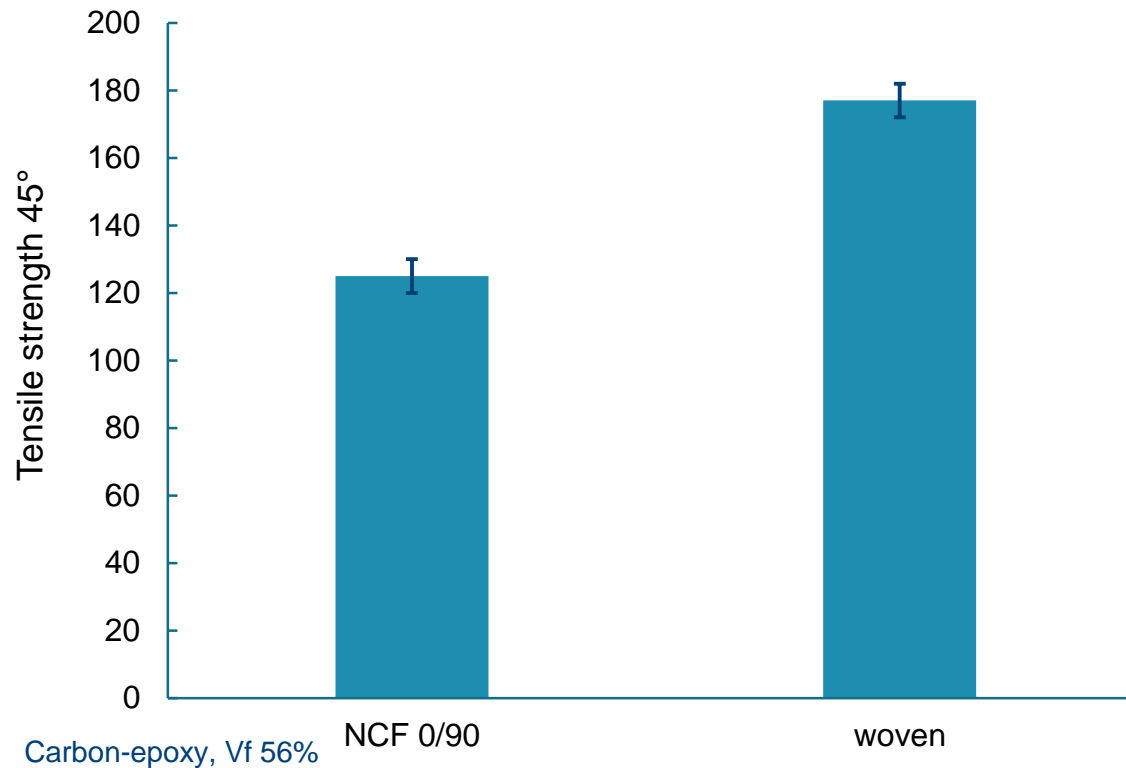

Strength

- Bias-direction tensile strength

Note: stitching in NCF can also affect bias strength:

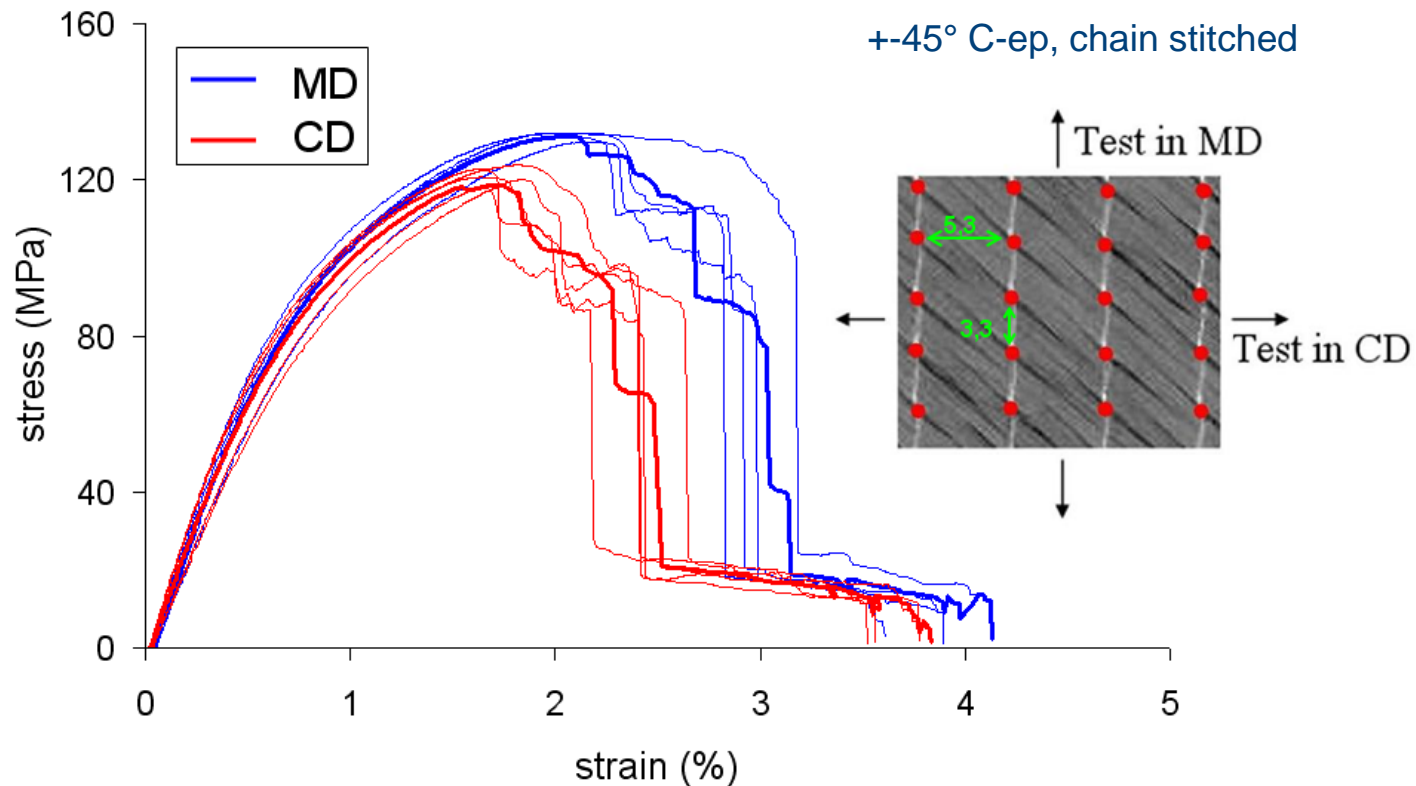

Strength

- Shear and bending strength
 - Effect of crimp/weave pattern

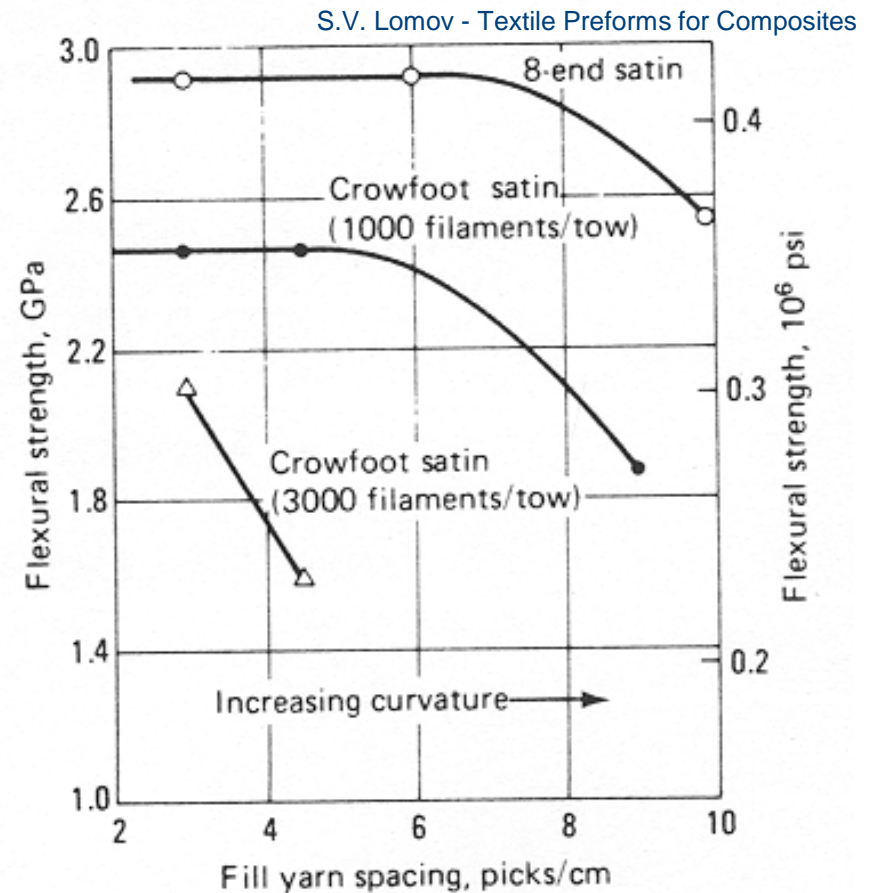
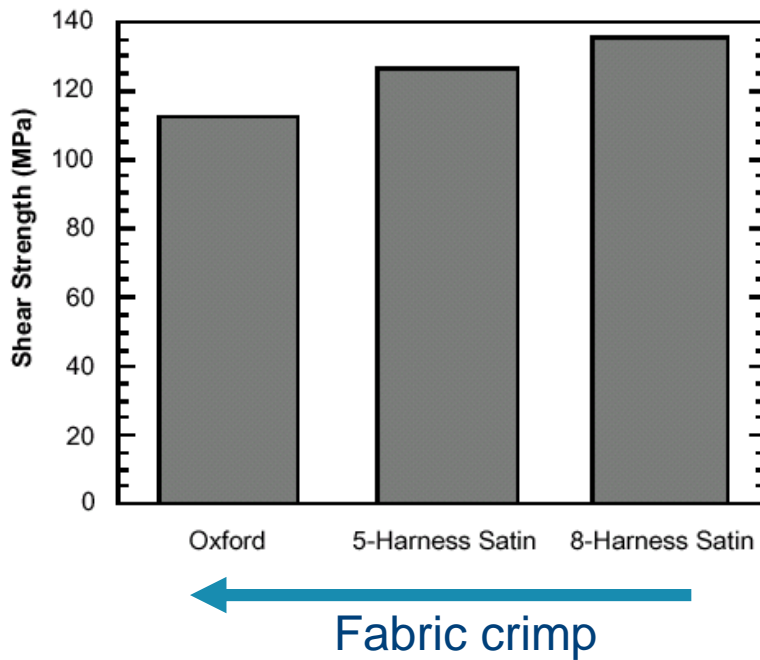

Strength

- In-plane compression strength
 - Crimp decreases buckling resistance

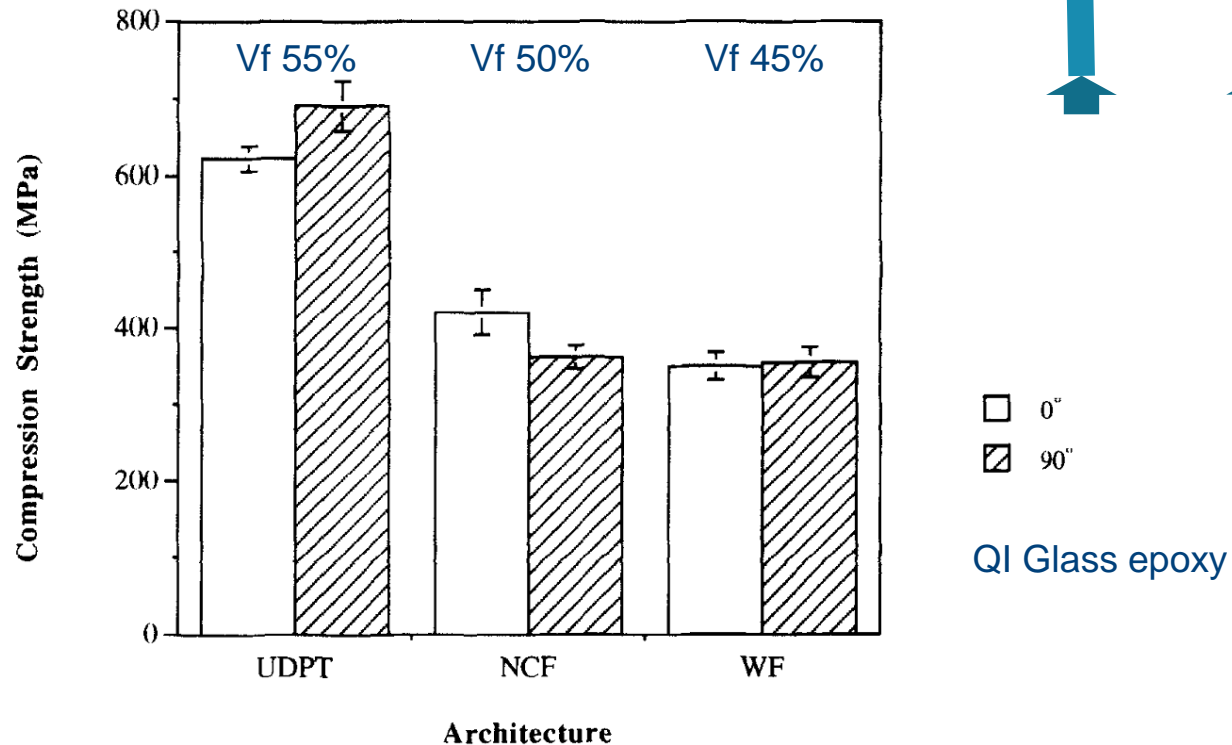

G. A. Bibo, P. J. Hogg, and M. Kemp, *Compos Sci Technol*, vol. 57, no. 9–10, 1997.

Strength

- Compression strength

Static compressive strength of glass fiber–epoxy composites using IITRI test

	Sample codes	Density (g cm ⁻³)	Fiber volume (%)	Composite thickness (mm)	Compressive strength (MPa)
NCF	LM	1.90	53	4.41	438 ± 10
Plain weave	PW	1.98	58	4.40	380 ± 8
Various structurally stitched	US 20	2.00	59	4.40	380 ± 6
	BS 20	1.90	53	4.58	386 ± 16
	US 10	2.0	59	4.35	385 ± 5
	BS 10	1.93	55	4.55	398 ± 8
	US 5	1.95	56	4.40	400 ± 9
	BS 5	1.95	56	4.60	427 ± 8

B. Yang et al, *Composites Part B*, vol. 31, no. 8, 2000.

Tensile fatigue

- Repeated tensile load
- Reinforcement architecture can cause differences in
 - fatigue life
 - damage development
 - residual properties

Tensile fatigue

- Fatigue life:
 - Q-UD NCF vs UD

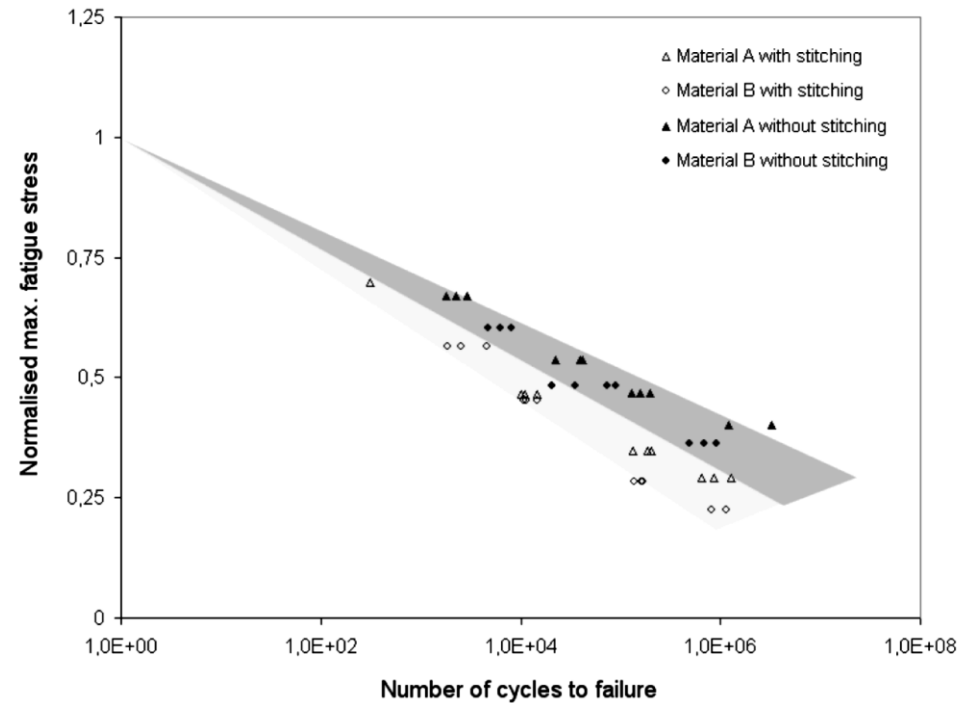
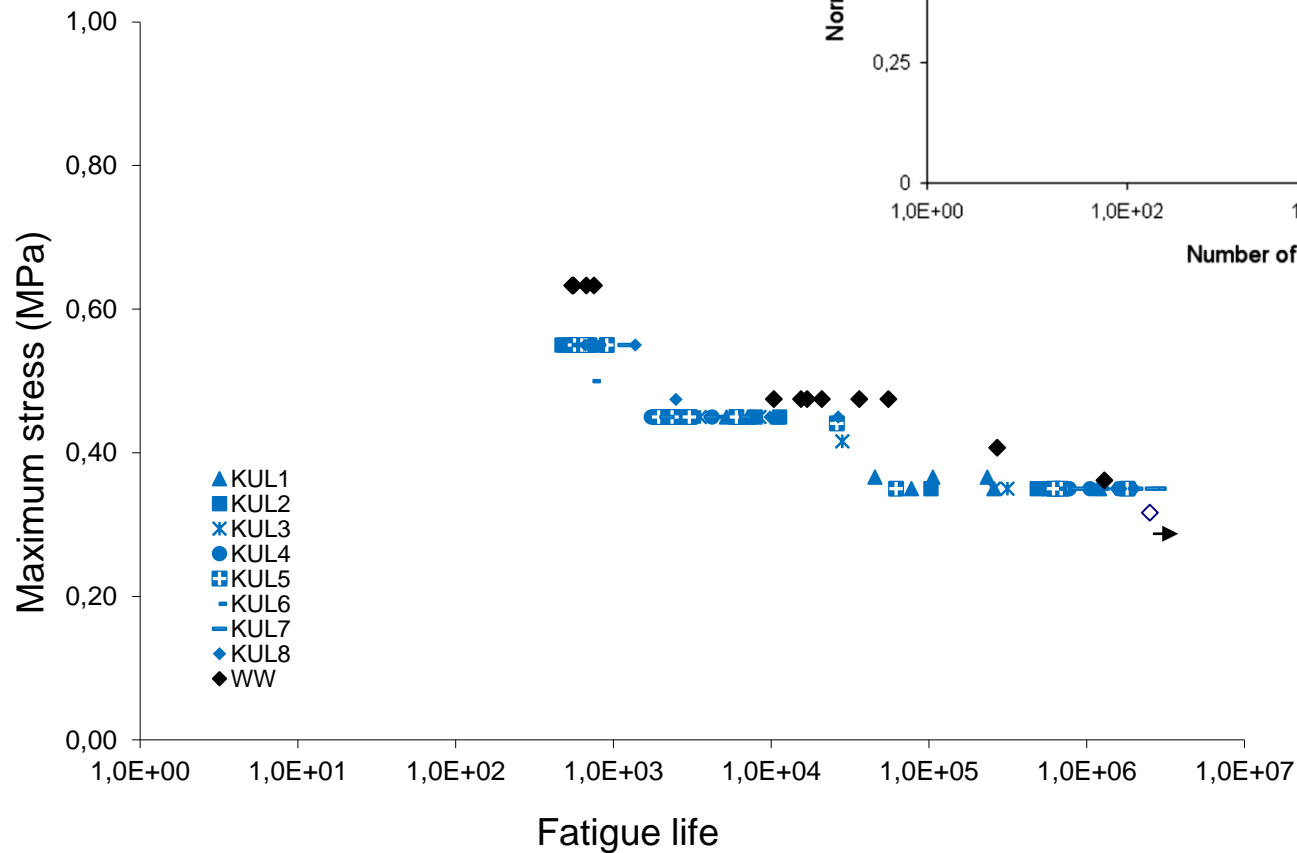

Tensile fatigue

- Fatigue life:
 - NCF vs woven (note: very low crimp twill weave!)

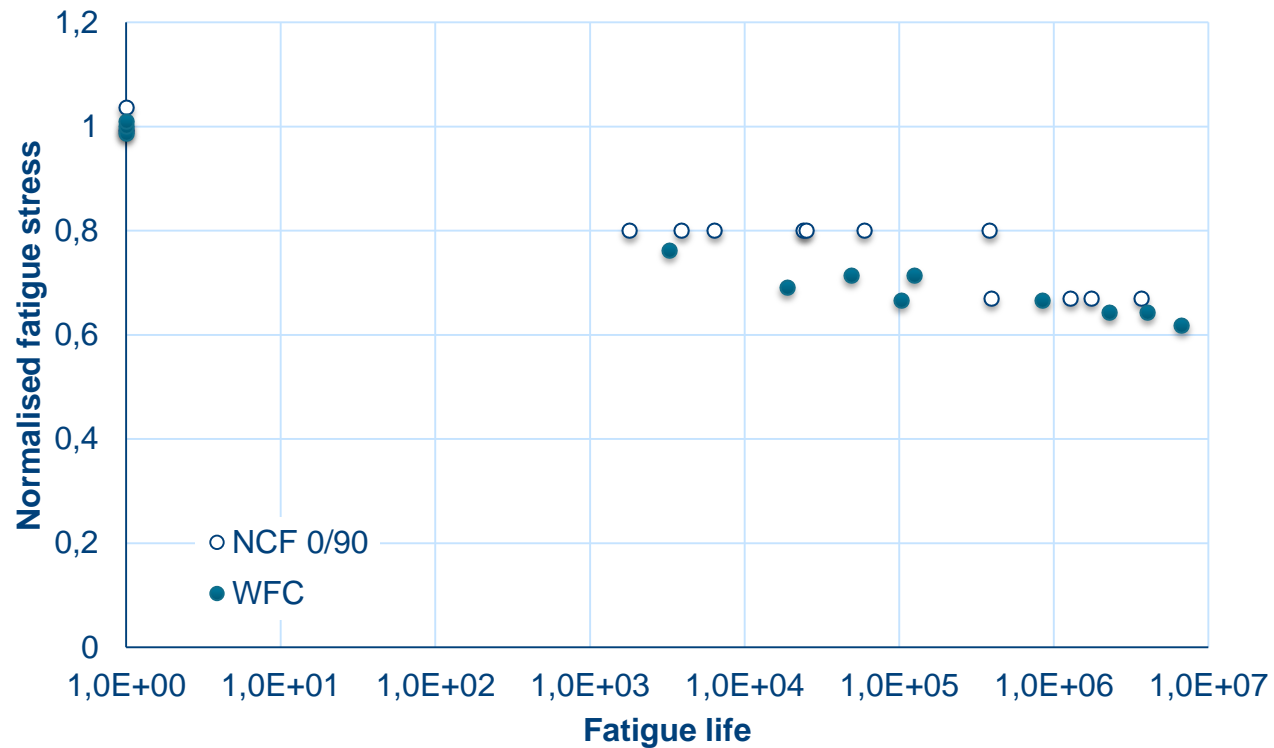

Tensile fatigue

- Fatigue damage:
 - similar to static case:
 - UD ~ NCF < Woven

C-ep, fatigue at 70% of UTS

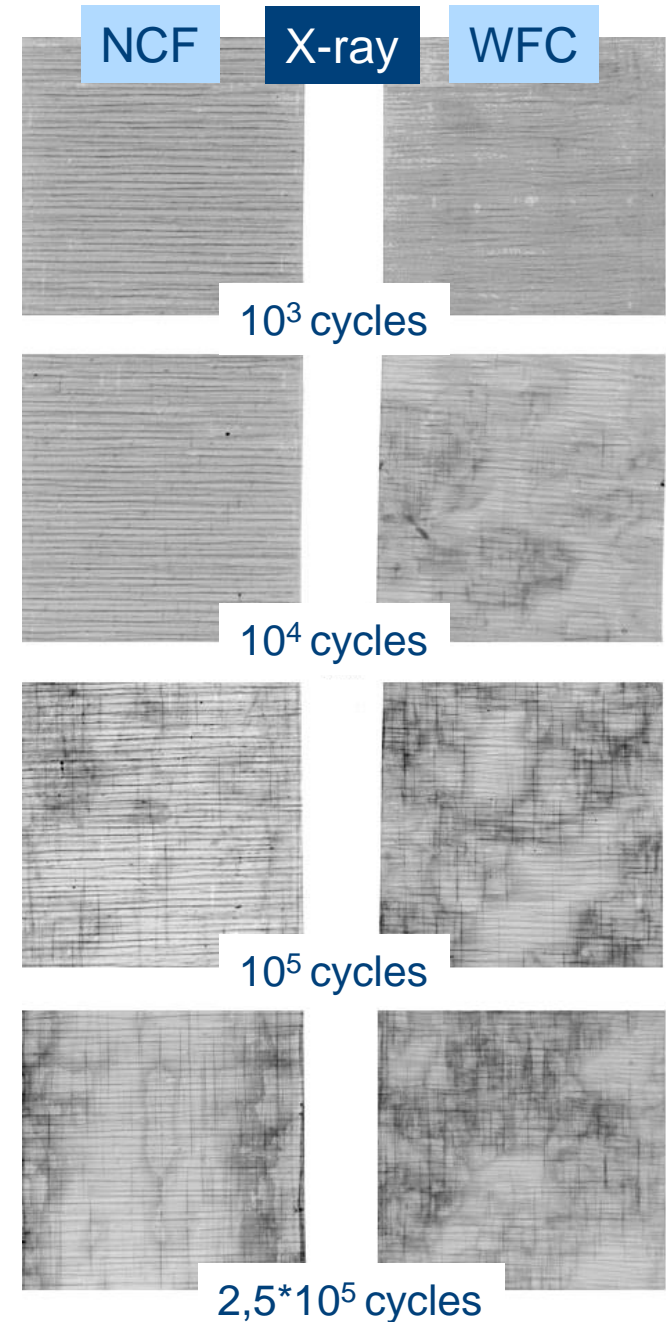
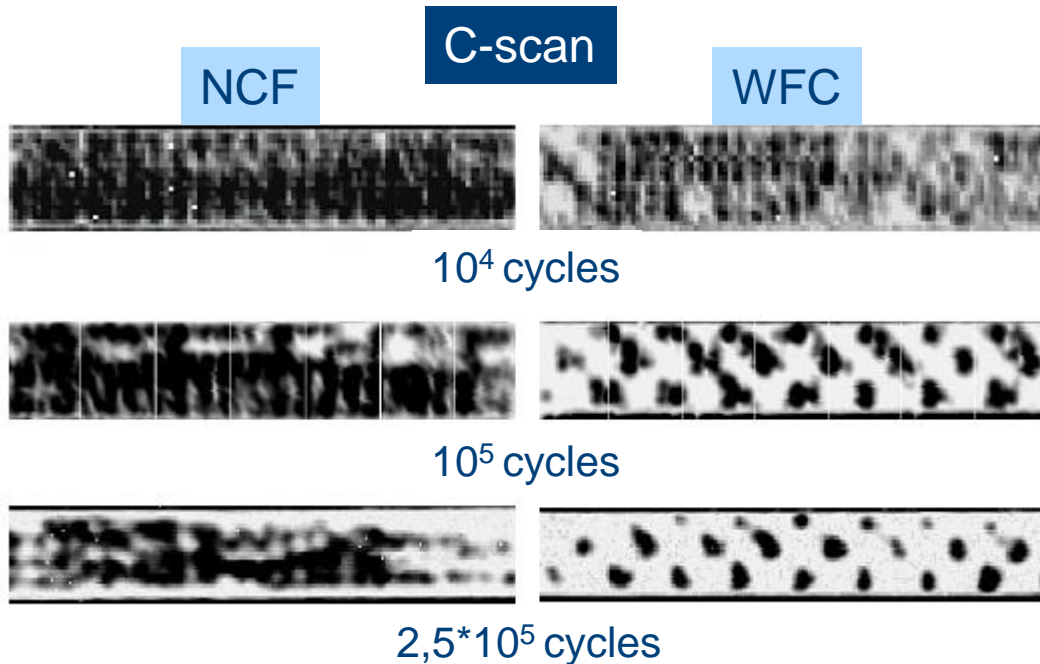

Tensile fatigue

- Stiffness evolution

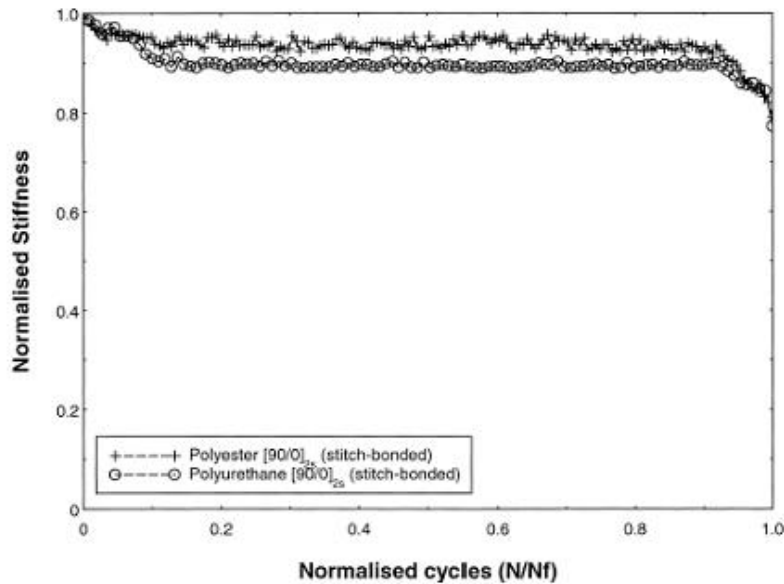

Dyer et al., Composites part B, 1998

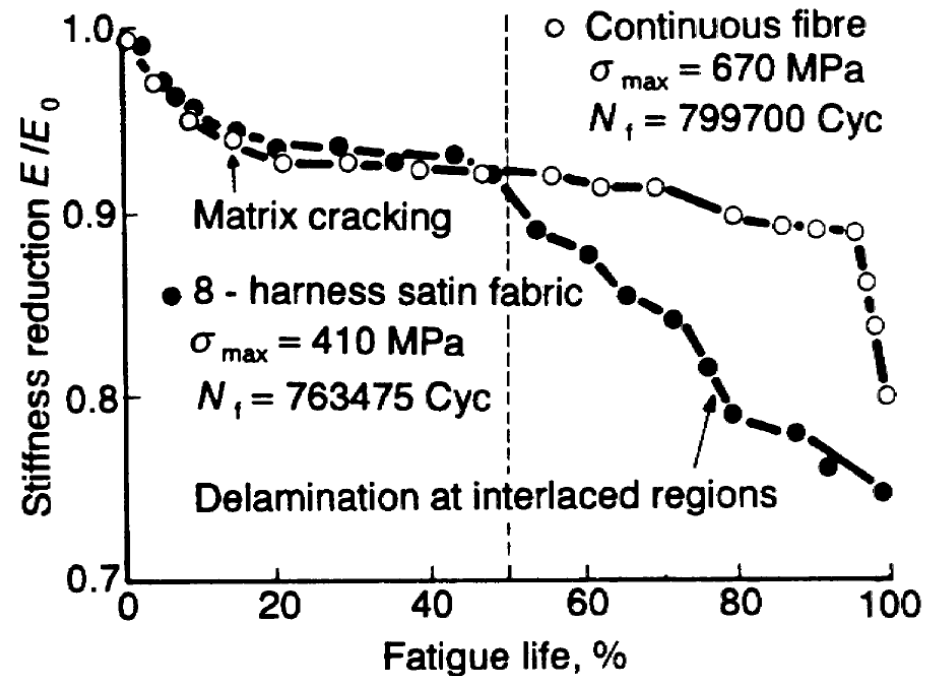
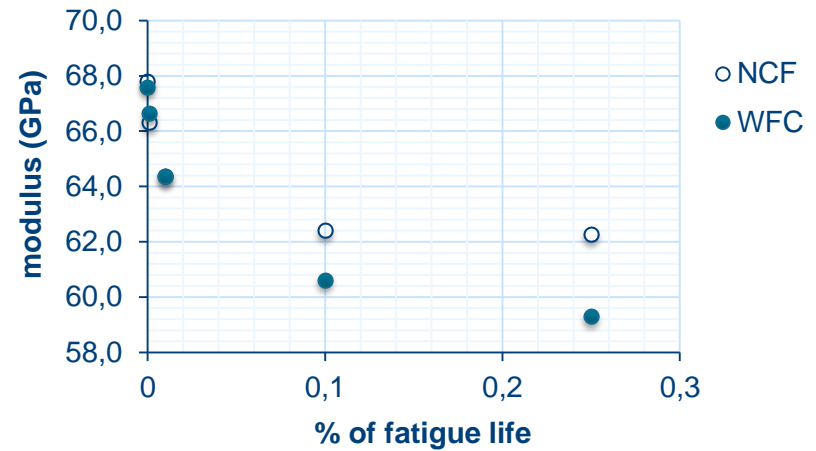

Talreja, Comprehensive composite materials, 2000

Tensile fatigue

- Residual compression strength
 - Woven: more delaminations than NCF → lower strength

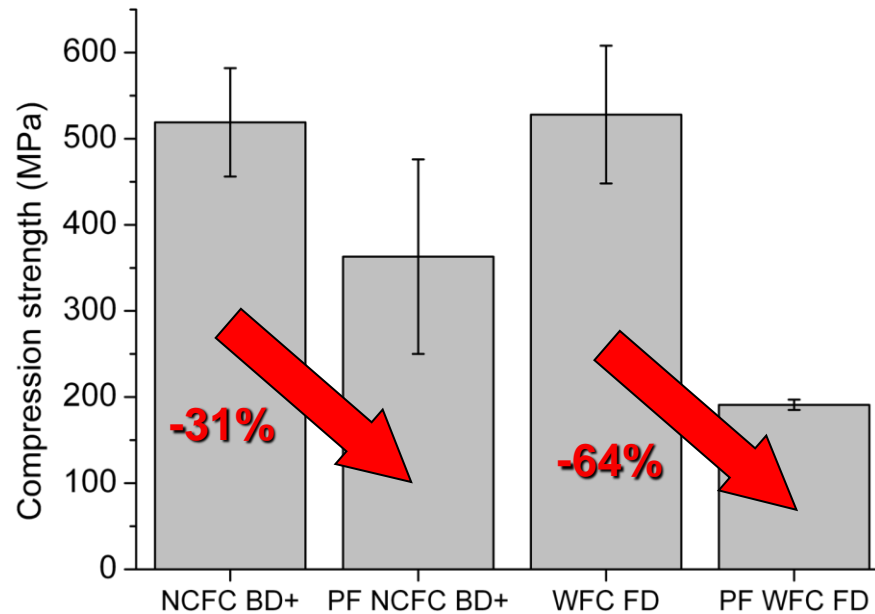

C-ep, fatigue at 70% of UTS, compression test after $2,5 \cdot 10^5$

Toughness and impact

- Interlaminar fracture toughness:
 - Resistance to delamination under tensile/ shear loading

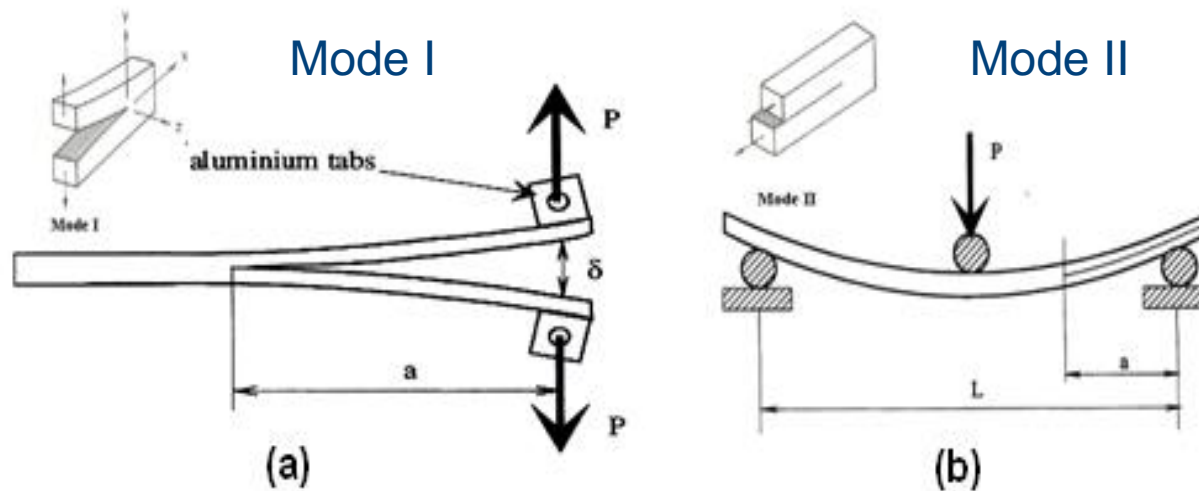

Toughness and impact

- Interlaminar fracture toughness:
 - Typically higher for woven fabric composites than for NCF/UD composites

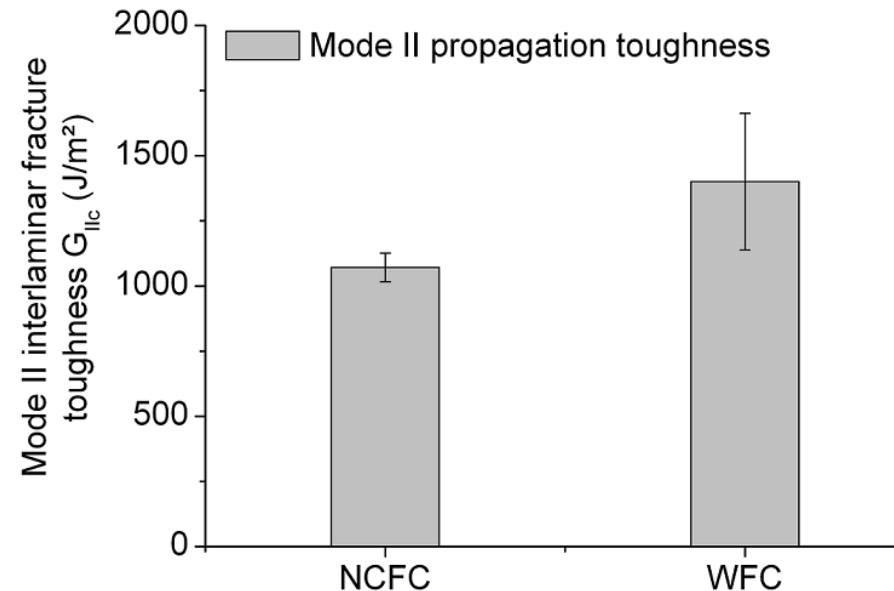
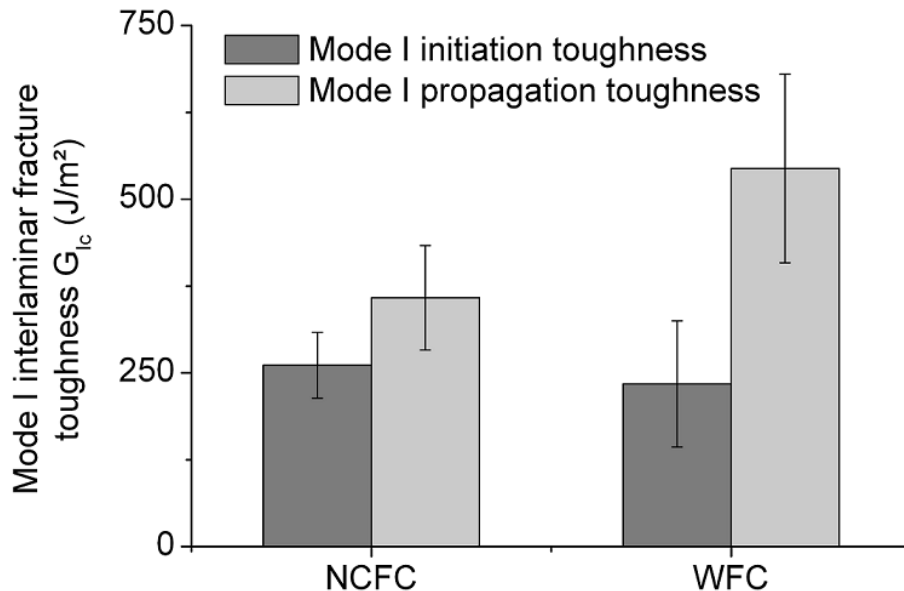

Toughness and impact

- Interlaminar fracture toughness:
 - Typically higher for woven fabric composites than for NCF/UD composites:
 - Crack path in UD/NCF is ~ straight, stitching in NCF has no effect if not structural
 - Crack path in woven composite must follow undulations of fabric, change in direction requires energy
 - more crimp → higher G_c

Toughness and impact

- Interlaminar fracture toughness:
 - Can be improved by through-thickness reinforcements e.g. structural stitching, 3D textiles

Specimen		G_{IRs} (kJ m ⁻²)	Improvement factor
Unstitched	Untabbed	0.41 ± 0.02	—
	Tabbed	0.44 ± 0.05	—
2-ply Kevlar [®] 4 stitches cm ⁻²		2.03 ± 0.04	4.6
2-ply Kevlar [®] 4 stitches cm ⁻² (1)		0.98 ± 0.09	2.2
2-ply Kevlar [®] 8 stitches cm ⁻²		2.82 ± 0.09	6.4
2-ply Kevlar [®] 12 stitches cm ⁻²		4.10 ± 0.25	9.3
3-ply Kevlar [®] 4 stitches cm ⁻²		2.59 ± 0.11	5.9
4-ply Kevlar [®] 4 stitches cm ⁻²		2.90 ± 0.12	6.6
4-ply Kevlar [®] 8 stitches cm ⁻²		4.54 ± 0.10	10.3
T900 carbon 4 stitches cm ⁻²		4.02 ± 0.13	9.1
T900 carbon 8 stitches cm ⁻²		6.42 ± 0.05	14.6

L. K. Jain et al., *Composites Science and Technology*, vol. 58, 1998.

Toughness and impact

- Drop-weight impact:
 - Large interlaminar stresses
 - Interlaminar toughness important
 - Woven fabric structure prevents splitting of back plane

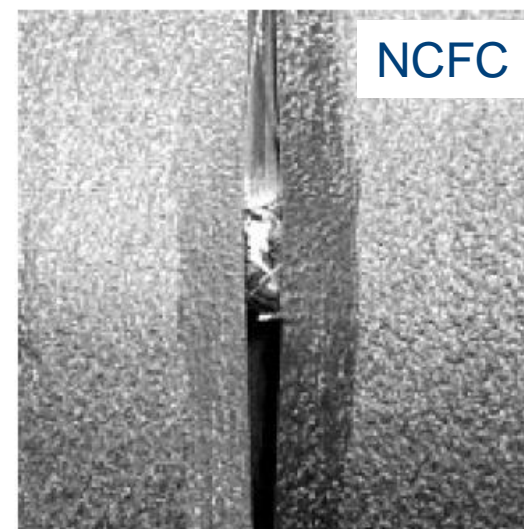
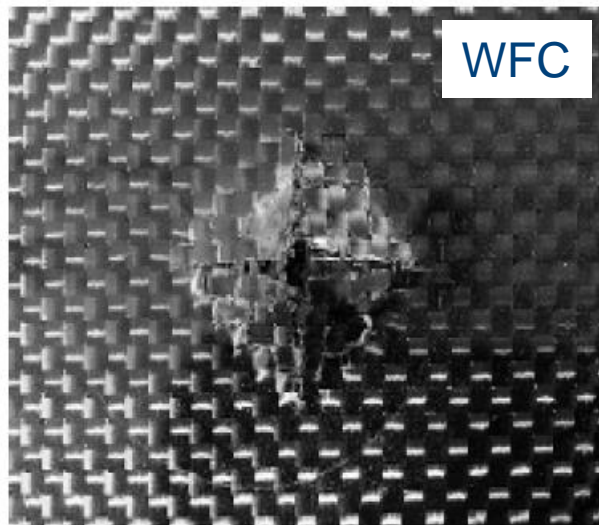
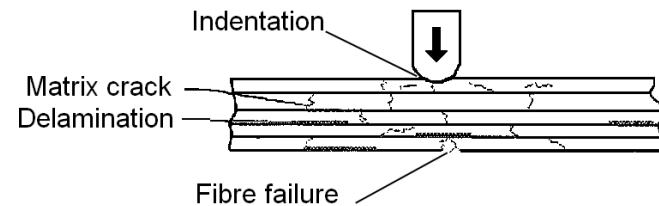
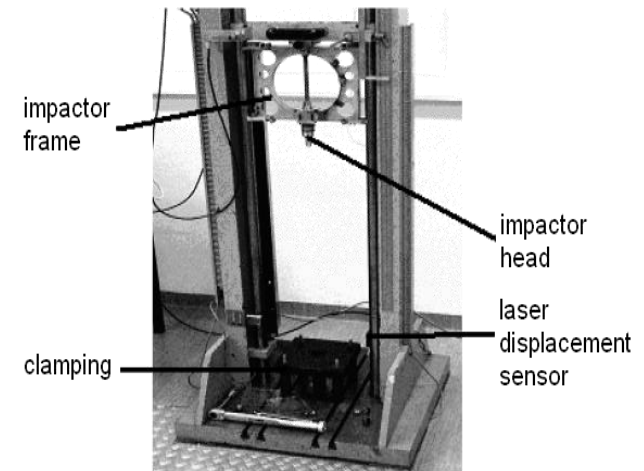

Toughness and impact

- Drop-weight impact:
 - Delamination area: UD~NCF >> Woven
 - Residual properties: UD~NCF << Woven

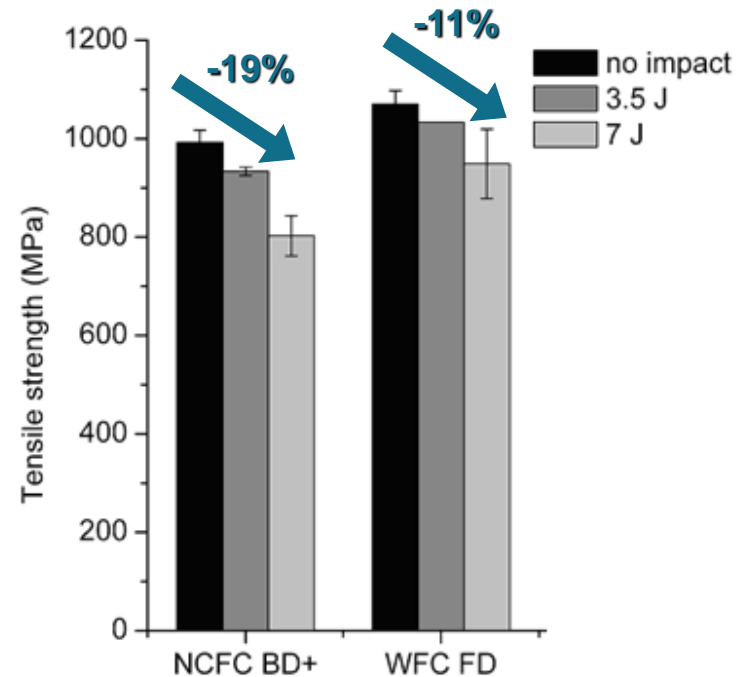
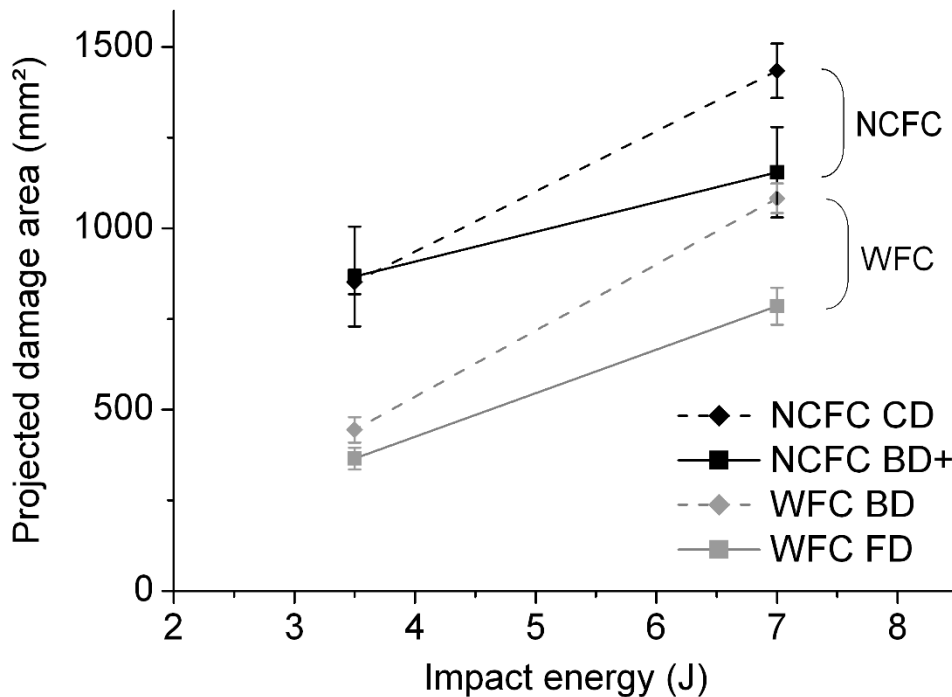

Toughness and impact

- Drop-weight impact:
 - Structural stitching, 3D textiles improve also impact resistance (but lower in-plane properties)

Summary

- Textile **crimp** is the main reason textile composite properties are generally lower than UD-based composite properties
- Textile (and fibre bundle) parameters determine amount of crimp
- Typically, fibre-direction in-plane stiffness and strength decrease as:

UD > NCF > Woven/braided

- WF composites are more prone to delamination formation under tensile load

Summary

- Fabric artefacts e.g. stitching sites can initiate damage
- Toughness and impact properties of woven composites are generally better than those of UD-based or NCF composites
- New types of reinforcements are developed to overcome weaknesses: structural stitching, 3D textiles,...
- 'Best' reinforcement architecture depends on application

Thank you for your
attention

Any questions?

KU LEUVEN